

INTERMEDIATE TRANSFORMERS

MARCH 21
1931

15¢
Per Copy

MIDGET CIRCUIT

RADIO

REG. U.S. PAT. OFF.

WORLD

The First and Only National Radio Weekly
469th Consecutive Issue—TENTH YEAR

BALANCING A
SUPER'S MIXER
WITHOUT TUBES

SHORT-WAVE
CALIBRATION

ANY SET EASILY MADE SELEC- TIVE

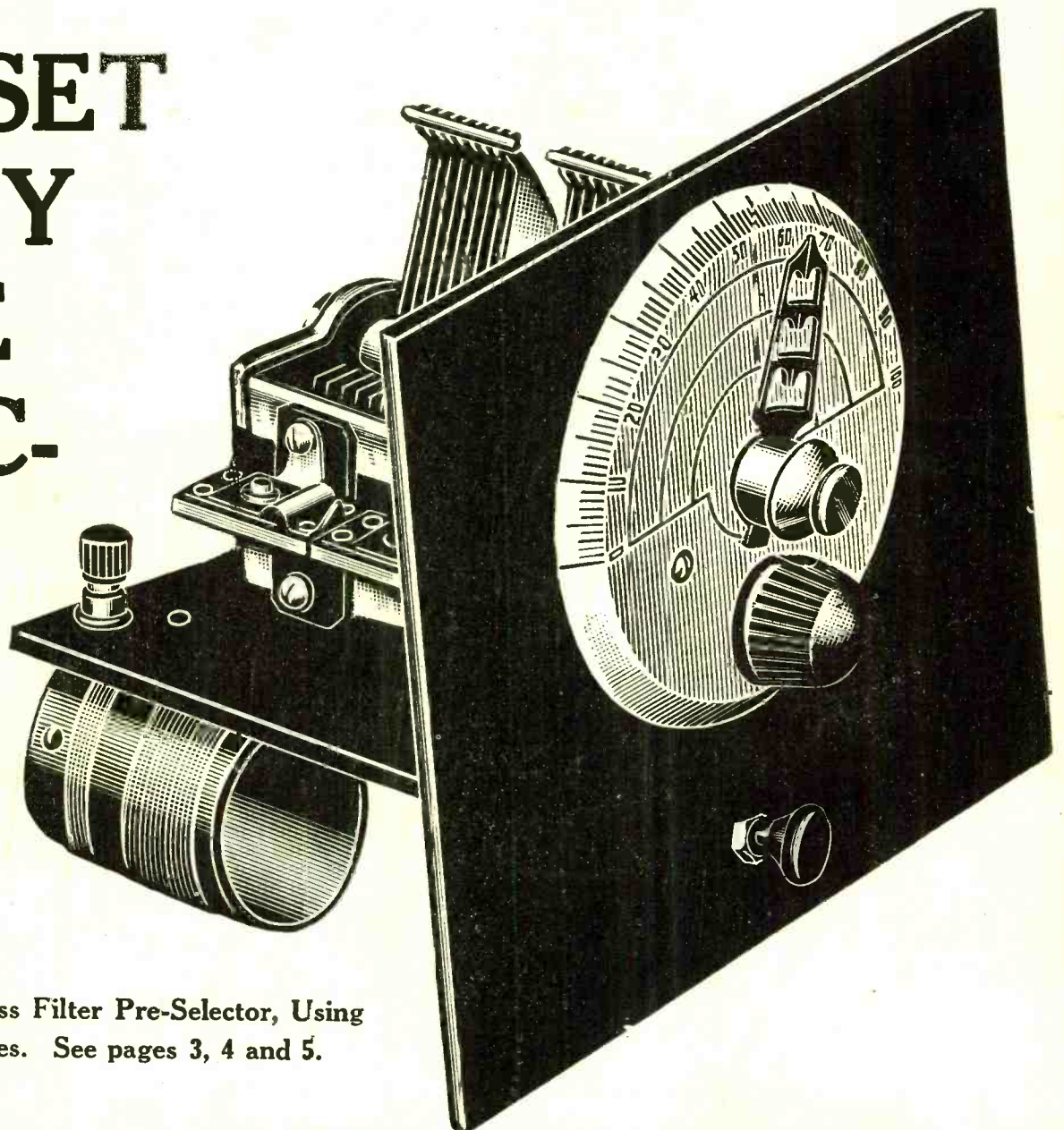

A Band Pass Filter Pre-Selector, Using
No Tubes. See pages 3, 4 and 5.

POLO DX-4 CONVERTER

10 TO 600 METERS WITH POWER SUPPLY BUILT IN

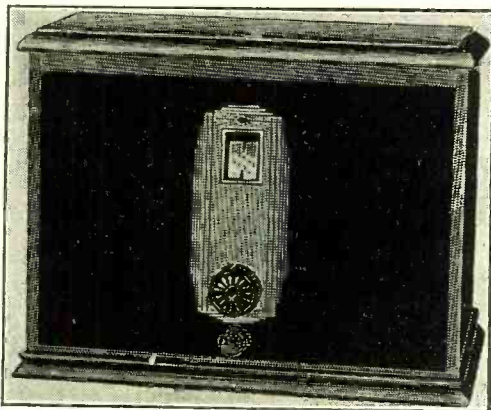

The DX-4 All-wave Converter uses a National modernistic dial to tune with the Hammarlund condenser. An AC switch is built in. Note the attractive panel appearance.

New Hammarlund short-wave midget condenser; turns in 2-inch diameter; frame depth 27/16 inches; 27 tiny plates; capacity is .0002 mfd. Order Cat. H-20 at.....\$1.35
 Tube base type short-wave plug-in coils for 30-600 meter mixer when used with .0002 mfd. Total, two coils for 5-prong tube base as coil receptacle. Order Cat. L-156 (both coils) at.....\$1.20

National modernistic flat type dial, with pilot lamp and bracket, for condensers that increase capacity clockwise; fits Hammarlund .0002 mfd. correctly. Order Cat. ND at.....\$2.95
 Set of three precision plug-in coils for Polo DX-4 Converter. 3" diameter; wound on air. Tunes from 15 to 600 meters in any converter with .0001 to .0002 mfd. maximum. Order Cat. LXX-4 at.....\$4.50

POLO PRECISION POWER EQUIPMENT
 POWER TRANSFORMER for 300 volts DC output at 100 wa, using 280 rectifier; 16 amperes 2 1/2 volt secondary for up to eight heater type tubes, besides two secondaries for the 280 and one for filament of up to two 245s. Connections brought out by insulated flexible wire leads. In polished aluminum shielded case. Order Cat. 245-PT @.....\$6.00

B SUPPLY CHOKER, rating 30 henrys, DC resistance 200 ohms; stands up to 100 wa. Has four insulated wire leads. Black goes to rectifier, red connects to first filter capacity; green to second filter capacity; yellow output impedance (black and yellow to push-pull plates, green to B plus). In polished aluminum shielded case. Order Cat. 245-CH @.....\$3.00

POLO ENGINEERING LABORATORIES

125-B WEST 45th STREET, NEW YORK CITY

Telephone BRyant 9-8093

Models on Exhibition

SELECTIFIER BAND PASS FILTER

Makes Any Set Selective

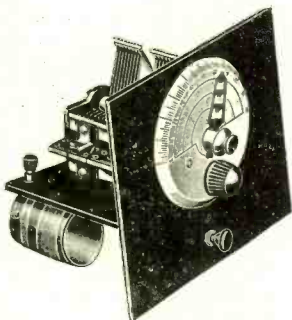

A NEW product of the Supertone Products Corporation is the Selectifier, which makes any set selective. This device is a band pass filter with 10 kc. band width and enables you to separate any station from any other, build up the volume of weak stations, subdue powerful locals so they are no longer troublesome, and bring in far greater distance, and more of it, than you ever thought possible with your set.

Many persons own sets excellent in every respect, except for insufficient selectivity. Why not capitalize on the heavy investment already made, by installing a Selectifier, and rid yourself forever of interference from other stations, due either to crosstalk or crossmodulation?

By tuning the Selectifier to the same frequency as that of an interfering station, that interference is totally eliminated. By tuning the Selectifier to the frequency of a desired station, the volume of that station is approximately doubled.

Not only is the Selectifier an interference eliminator and volume booster, but it is also an accurate frequency meter for broadcast frequencies, since the tuning curve is obtainable. A conversion table, also furnished, makes the Selectifier a wave meter, so you can tell either wavelength or frequency.

So, even if your set is not calibrated in kilocycles or meters, you can tune the Selectifier to the desired frequency or wavelength, and then turn the dial of your set without looking at that dial, to bring in the desired station.

There are only three connections to make: (1) Remove the aerial from the antenna post of your receiver and connect it instead to the antenna post of the Selectifier; (2) Connect a wire from the ground of your set, leaving ground connected there, to the ground post of the Selectifier; (3) Connect the blank output post of the Selectifier with a wire to the vacated antenna post of your set.

The Selectifier, a band pass filter pretuner, has two ganged tuned circuits. No tubes are used in it. Get one of these new Selectifiers right away! Enjoy real selectivity without sideband-cutting. Modernize your set by endowing it with a band pass filter. If you are not overjoyed with the Selectifier's performance, return it after you've had it for not more than five days, and we will promptly refund your money!

Supertone Selectifier, wired model, on 7 x 7 inch front panel, in an attractive cabinet, order Cat. SEL @ \$10.00. Calibration curve and conversion table for constituting the Selectifier a frequency meter and wave meter, order Cat. CC @ 50c.

FIXED-FREQUENCY TRANSFORMER

A DOUBLY tuned fixed-frequency transformer, 1 to 1 ratio, tuned to 175 kilocycles, contained in a 2-inch diameter aluminum shield, 2 3/4 inches high, with anchored base and top and bottom mounting screws, is another of Supertone's new products. Two loosely coupled high-inductance choke coils constitute primary and secondary. Across each winding is a tuning capacity accessible to a screwdriver through shield holes. Suitable for all uses where 175 kilocycle frequency is desired, and affording high selectivity, without sideband cutting. The transformer may be mounted on the side of a chassis, in horizontal position, or upright either above or below the chassis top.

Supertone Fixed-Frequency transformer, for screen grid tubes, tuned to 175 kc., with tuning condensers across primary and secondary, both accessible; in aluminum shield 2-inch diameter, 2 3/4 inches high, with anchored bottom, both horizontal and upright mounting facilities. Order Cat. FF-175 @ \$3.00.

For other than screen grid tubes (secondary alone is tuned, ratio is 1 to 4). Order Cat. FF-175-G @ \$2.65.

SUPERTONE PRODUCTS CORPORATION

216 Wallabout Street

Brooklyn, N. Y.

SOLDERING IRON FREE!



Works on 110-120 volts, AC or DC; power, 50 watts. A serviceable iron, with copper tip, 5 ft. cable and male plug. Send \$1.50 for 13 weeks' subscription for Radio World and get these free! Please state if you are renewing existing subscription.

RADIO WORLD

145 West 45th St.

N. Y. City

SHIELDED LEAD-IN WIRE

No. 18 solid wire, surrounded by a solid rubber insulation covering, and above that a covering of braided copper mesh wire, which braid is to be grounded, to prevent stray pick-up.

Also used to advantage in the wiring of receivers, as from antenna post of set to antenna coil, or for plate leads, or any leads, if long. Order Cat. SH-LW. List 9c, net, 5c per ft.



This wire is exceptionally good for antenna lead-in, to avoid pick-up of man-made static, such as from electrical machines.

Also used to advantage in the wiring of receivers, as from antenna post of set to antenna coil, or for plate leads, or any leads, if long. Order Cat. SH-LW. List 9c, net, 5c per ft.

GUARANTY RADIO GOODS CO.

143 West 45th St., New York, N. Y.

Three 0.1 mfd. in One Case

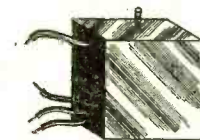

Three Supertone non-inductive fixed condensers of 0.1 mfd. each, (250 v.) in steel case, provided with a 6/32 mounting screw, built in. The black lead is common to the three condensers, the three red leads are the other sides of the respective capacitors. Size, 1 1/2" square by 3/8" wide. Order Cat. SUP-31, list price, \$1.00; net price, 57c.

GUARANTY RADIO GOODS CO.

143 West 45th St., New York, N. Y.

FIDELITY HORN UNIT—Stands up to 450 volts without filtering. Can be used in the portable without horn attached. Price, \$2.25. Guaranty Radio Goods Co., 143 W. 45th St., New York.

Set of SOCKET WRENCHES FREE



FOR turning nuts down or up there is nothing as efficient and handy as a socket wrench. Here is a set of three wrenches for hexagonal nuts, enabling use with 5/32, 6/32, 8/32 and 10/32 nuts. Fit the nut into the proper socket and turn down or up. The three different size sockets, one size on each wrench, enables use of three different outside diameters of nuts, but at least ten different sizes of threads. Send \$1.00 for eight weeks subscription for RADIO WORLD and get this set of three wrenches FREE!

RADIO WORLD, 145 W. 45th St., New York, N.Y. Enclosed \$1.00 for 8 weeks. Send wrenches.

Name

Address

City..... State.....

Cross here if extending existing subscription.



Vol. XIX. No. 1. Whole No. 469
 March 21st, 1931
 [Entered as second-class matter, March
 1922, at the Post Office at New York,
 N. Y., under act of March, 1879]
 15c per Copy, \$6.00 per Year

TENTH YEAR
 Technical Accuracy Second to None
 Latest Circuits and News

A Weekly Paper published by Hennessy
 Radio Publications Corporation, from
 Publication Office, 145 West 45th Street,
 New York, N. Y.
 (Just East of Broadway)
 Telephone, BRyant 9-0558 and 9-0559

RADIO WORLD, owned and published by Hennessy Radio Publications Corporation, 145 West 45th Street, New York, N. Y. Roland Burke Hennessy, president and treasurer, 145 West 45th Street, New York, N. Y.; M. B. Hennessy, vice-president, 145 West 45th Street, New York, N. Y.; Herman Bernard, secretary, 145 West 45th Street, New York, N. Y.; Roland Burke Hennessy, editor; Herman Bernard, business manager and managing editor; J. E. Anderson, technical editor.

A Band Pass Pre-Tuner

By Einar Andrews

THERE is much need for a pretuner for making receivers more selective, because there are many sets which, while exceedingly sensitive, are not sufficiently selective to separate all the stations or to prevent cross talk and cross modulation. Many receivers which have a sufficient number of selective tuners after the first tube do not have enough in front of that tube and for that reason are not selective enough to prevent cross-modulation, which occurs primarily in the first tube. In such cases a pretuner is a convenient and effective remedy.

But such a tuner must itself be very selective or it will not perform its intended function, but only reduce the sensitivity of the receiver. If it is selective the small reduction in the sensitivity of the receiver which it may cause at the lower wavelengths can be more than offset by operating the tubes in the set at a more favorable combination of voltages than they could be without the pretuner, or a switch to vary coupling may be included in the selector. A pretuner of this kind is valuable in that for a small extra cost it is often possible to save a receiver which costs 10 times as much, or more, and to transform the receiver into one that the owner hoped it would be when he bought it.

Band Pass Filter Tuner

While a pretuner may consist of a single tuned circuit much better selectivity can be obtained with two loosely coupled circuits connected in the form of a band pass filter such as is illustrated in Fig. 1. In this circuit we have first a transformer with a primary of 15 turns and a secondary of 70 turns, coupled loosely. The secondary, or 70-turn, winding is tuned with one section of a double condenser. Then we have another similar tuned circuit with the 70-turn winding for primary and the 15-turn winding for secondary, the primary being tuned with the second section of the double tuning condenser.

These two tuned circuits are coupled loosely by means of a 0.05 mfd. fixed condenser shunted, if desired, by a 500 ohm resistance, although the resistance may be omitted. The condenser primarily constitutes the coupler between the two tuned circuits and the degree of coupling is loose because the condenser is so large. The degree of coupling varies with the frequency, becoming looser as the frequency increases almost in direct proportion as the need for reduced coupling changes. The coupling must be less at the higher frequencies because the stations are relatively closer together and also because the broadcast receiver is usually much less selective at these frequencies.

Variation of Coupling

Provision is made for varying the coupling in case closer coupling is desired, which is likely in some instances on the lower broadcast frequencies. The provision consists of a 100 mmfd. condenser, connected between the stators of the two sections of the variable condenser and a switch in the line so that this condenser may be removed when not needed or desired. The 100 mmfd. condenser has a range from 20 to 100 mmfd. and the main object of the switch is to cut out the 20 mmfd., since this cannot be removed by adjusting the condenser.

To insure perfect alignment of the two sections of the double variable condenser a 100 mmfd. trimmer is connected across each section. When the two 70-turn windings are exactly of the same inductance and the coupling of each to its 15-turn winding is loose, as is the case, it is possible to align the condensers throughout the tuning range so that the selectivity of the tuner is high. However, should there be any deviation from

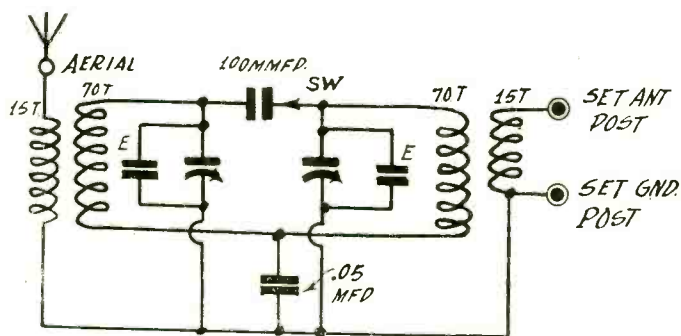

FIG. 1

The circuit of a pretuner in the form of a band pass filter which may be used to sharpen broad receivers and for minimizing cross talk.

perfect alignment in some instances the trimmers may be adjusted in that part of the tuning range where greatest selectivity is required. Since the small series condenser may be cut in or out by means of the switch SW it is really possible to align the circuits at two points so that the deviation from perfect alignment need never be appreciable in case there is any at all.

Construction of Pretuner

The physical construction of the band pass filter or pretuner is shown in Fig. 2, the double condenser being placed between the two equal coils. The two trimmer condensers may be seen mounted on the tuning condensers.

The coil and condenser assembly is placed on a suitable panel and subpanel and provided with a vernier dial by which the condensers are turned.

The dial may be calibrated once the trimmer condensers have
 (Continued on next page)

LIST OF PARTS

Coils

Two radio frequency transformers with 15-turn and 70-turn windings on 1.75 inch bakelite tubing, No. 28 enameled wire.

Condensers

Three 100 mmfd. trimmer condensers.
 One two-gang Scovill .00035 mfd. tuning condenser.
 One 0.05 mfd. fixed condenser.

Other Parts

One switch.
 One REL dial.
 One 7x7 inch front panel.
 One 5½x4½ inch subpanel.
 Antenna; ground and blank binding posts.
 Four brackets to reinforce front and subpanels and support rear of subpanel.
 One cabinet to fit.

How to Make Any Cross Talk and Cross Modu

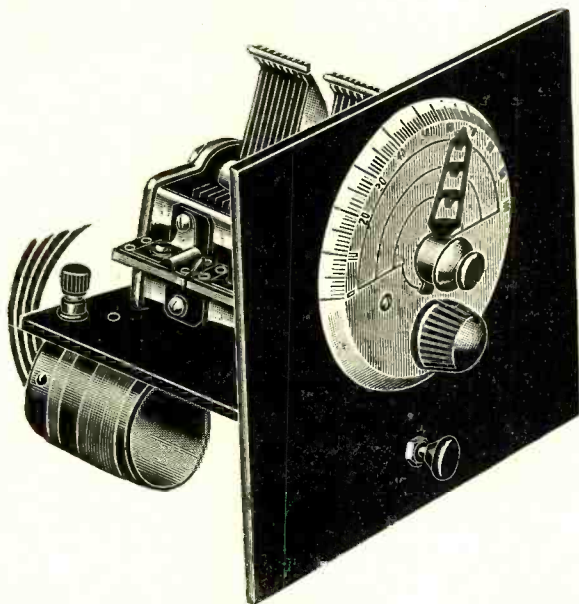

FIG. 2

The assembled pretuner and band pass filter comprising two tuning condensers and two radio frequency transformers together with means for coupling them.

(Continued from preceding page)

been adjusted so that the assembly may be used as frequency meter or a wave meter. This is a convenience which is often useful when a distant station, the frequency of which is not known, is tuned in. Quite frequently it is not possible to calibrate the broadcast receiver, especially at the short-wave end of the scale where the selectivity is poor.

When the circuit is calibrated it should be done with the switch open (pushed in) for then the coupling is the least and the selectivity is the greatest.

It has been pointed out that the 500 ohm resistance may be omitted without any appreciable change in the characteristic of the band passed. It is needed in other circuits, however, when the grid of the first tube is connected to the second condenser stator, that is, when the second 15-turn winding is omitted.

Effectiveness of Circuit

It might be supposed that the signal will be greatly reduced by the use of a step down transformer just ahead of the first tube, but this is not the case in general. If the input to the broadcast receiver is a low impedance winding the small secondary matches the input, improving the signal transfer without reducing the selectivity.

The circuit has been tested on many broadcast receivers and in every case the selectivity was improved and in most cases there was no decrease in the volume. When volume decrease appeared, the switch made up for the difference. The improvement was decidedly worth while. Of course, there are receivers so selective all over the scale that nothing else is needed. The pretuner is not necessary for such receivers, unless it be that the receiver is subject to cross talk, when every bit of extra selectivity ahead of the first tube is useful.

Helps Bring in More Distance

Besides improving selectivity, the band pass filter pre-selector also naturally improves the reception of distant stations, making it possible to bring in more of them, and to enjoy greater volume on those ordinarily received.

This asset of greater distance reception follows from the fact that selectivity and sensitivity are improved, because often a receiver has sensitivity without sufficient selectivity to provide the separation that enable the reception of particular distant stations, or, even if it is sensitive over part of the dial scale, it may be relatively insensitive over the rest of the scale, whereupon the band pass filter pre-selector atones for the shortcoming.

The increase in the power used by stations, which increase has been gradual during the past few years, and is still being carried on, makes it imperative to augment the selectivity of receivers designed in other days for other conditions. It is no reflection on the designers of those circuits that they did not anticipate the requirement for greater selectivity. However, since the difference between adequacy and inadequacy on the selectivity score may be easily remedied, the old set will give you quite a new kick when

you present it with a pre-selector, particularly of the band pass filter variety that affords selectivity increase without cutting of sidebands.

Data on Operation

It may be noticed in tuning the pre-selector that a seemingly contradictory situation arises, that is, at a particular setting for a given frequency of reception, the volume will be much greater, as stated, but that also on the other side of a midpoint the volume will be greater also, as compared with the midpoint.

This is due to the tuning characteristic of a band pass filter, which really consists of two tuned circuits slightly detuned in respect to each other, whereby there is a peak on either side of the depressed midpoint, and in actual tuning the midpoint reduces the volume of the station considerably.

The question to settle, and the only one, is whether to tune on one side or the other for the increase in volume that is so greatly desired on weak signals. The rule, in using this circuit, is to tune in on the side that requires the greater capacity, that is, higher numerical dial setting, in respect to the semi-silent midpoint. It will be found that the station can be tuned out more readily by slight detuning in the direction of greater capacity, whereas reducing the capacity may decrease the volume only slightly, even though the dial is turned all the way to zero.

Serves Two Purposes

It therefore is apparent that the pre-tuner serves two purposes: first, use as an acceptor circuit, where it favors the frequency selected; second, use as a rejector circuit, where it tends to elimi-

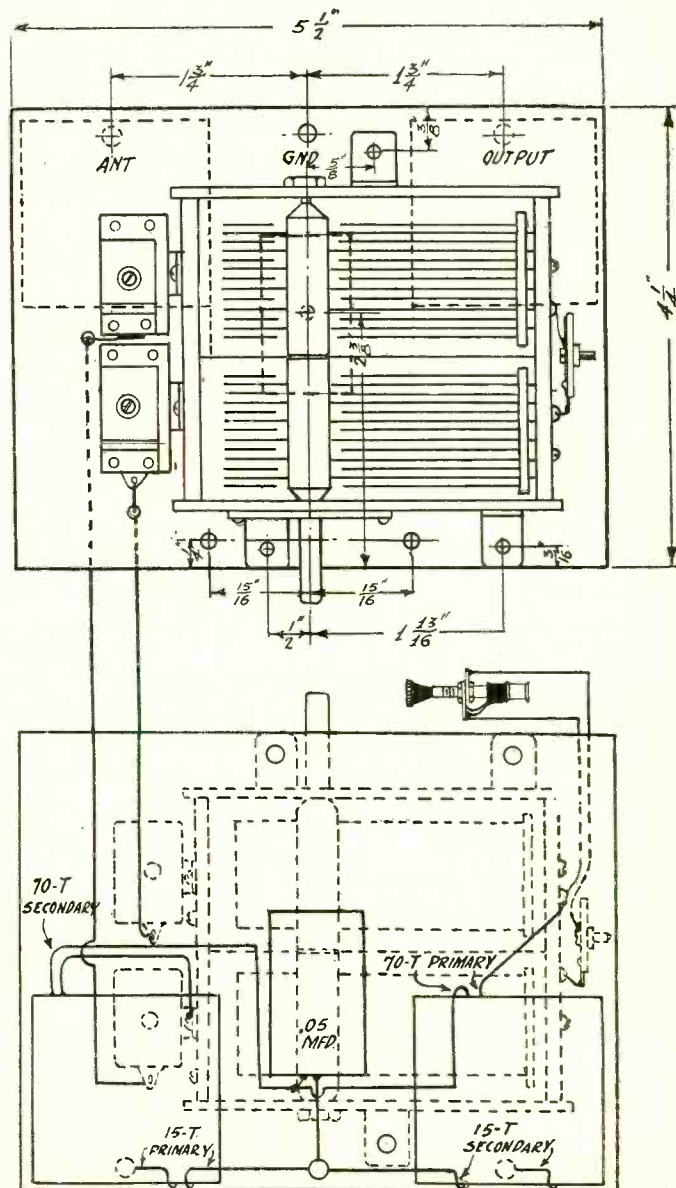

FIG. 3

The pictorial diagram of the wiring

Receiver Selective

Interference Eliminated; Set Calibrated

nate an undesired signal. This elimination point is the midpoint between the tuning peaks.

Therefore, to boost volume and sensitivity tune as directed for loudest response. If the object is to get rid of interference, as where a powerful local is close at hand, tune the midpoint to the undesired frequency, by reaching the midpoint for that frequency, apparent by volume reduction or elimination of the interfering signal, and then tune your set to the desired signal. The rejection feature, of course, constitutes the selector a wave trap, so you have your choice of two uses.

Questions Answered

Variation of Selectivity With Coupling

IN WHAT manner does the selectivity of a tuner vary with the coupling between the primary and the secondary? Does it increase or decrease as the coupling is increased?—S.G.H.

The selectivity decreases as the coupling increases. This is illustrated elsewhere in this issue by curves taken on an intermediate frequency transformer with tuned primary and secondary windings.

* * *

Loading Coil for Old Set

WHAT is the purpose of a loading coil? I have a Westinghouse R. C. set and understand one could be used with it.—M. L.

Yes, it will operate with your set, but not with modern sets. It is connected so as to increase the wavelength to which the set will respond. Principally useful to enable you to hear ship, commercial and other code communications above 550 meters.

* * *

AC on Power Tube

HOW is it possible to use AC direct on a power tube?—S. L. B.

Because there is no further amplification, so that the hum is not sufficiently noticeable to prove a source of interference.

* * *

Connections for Loop

IS it possible to use a loop antenna by connecting only one end to the antenna terminal of my set, or must I connect both ends together and to this terminal?—L. Z.

By connecting one end of the loop to the set, some success may be had, but results will be poor. The loop calls for a special receiving circuit. It is possible to adapt it to your set by a special connection, but the set should preferably be de-

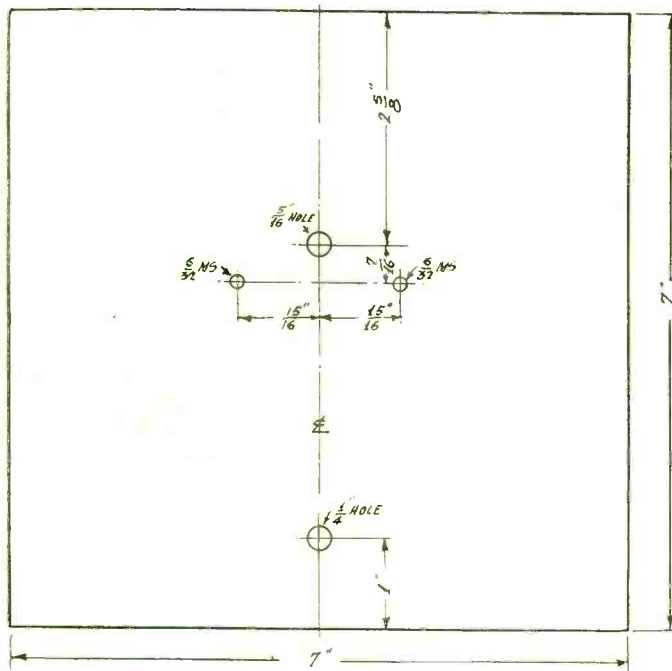

Fig. 4
Front panel dimensions.

signed for use with a loop. Extra amplification is necessary for this type antenna. It has decided advantages, such as directional reception, lower proportion of static, etc., but requires a more costly set for adequate results.

* * *

Neon Tube Explained

WHAT is a Neon tube, and can it be applied in a radio receiving outfit?—C. L. F.

The Neon tube is a tube with two similar elements or plates. The tube is filled with neon gas. The gas is electrically charged or ionized and glows faintly or brightly in accordance with the voltage applied to it. It can change its brilliance instantly, and is used in television reception on this account. It is not used in the usual type of radio set.

FREE AID TO A NEW JOB!

SITUATIONS WANTED AND HELP WANTED ADVERTISEMENTS WITHOUT COST!

Address: Industrial Dept., RADIO WORLD, 145 W. 45th St., N. Y. C.

SITUATIONS WANTED

YOUNG MAN, 22 YEARS OF AGE desires position in experimental laboratory or factory. Has over five years experience as radio service man, and also has had experience with sound and acoustical work. Will work anywhere in the U. S. or foreign country. Will start with a reasonable salary. Write Wm. Palmer, Box 167, Crystal, Va.

A-B-C POWER PACKS, 110 volt, 60 cycle, for sets using 1 1/2, 2 1/2 and 5 volt tubes or for electrifying battery sets. Packs are well made, filtered with Potter Condensers and are remarkably free from hum. Complete with 280 tube, \$6.25. Cash Radio, 1013 N. McDonei St., Lima, Ohio.

YOUNG MAN, 19, RADIO OPERATOR COMMERCIAL CLASS—desires position as operator either aboard ship or ashore. Familiar with all commercial procedure, and competent touch-typist. Write Harold J. May, 277 Morris Ave., Springfield, N. J., or phone Millburn 6-0623-M.

NATIONAL RADIO INSTITUTE GRADUATE—10 years' experience in radio service, desires position anywhere at anything. Prefers store work as combination salesman and radio service man. Has test equipment and tools. Can furnish bond and first-class references. Write National Radio Inst., Washington, D. C., Student No. 74A25 for information as to ability. H. M. Goodrich, Box 1301, Ft. Lauderdale, Fla.

GOOD SERVICE MAN, age 23, colored. 8 years' radio practice. Knows theory, power amplifiers, and laboratory apparatus. Will consider any radio work. P. Donald Carr, 6523 Evans Ave., Chicago, Ill.

RADIO GRADUATE OF THE I. C. SCHOOLS, with technical training both in servicing and construction, wishes steady job in store or factory. Francisco Bou, Jr., 4448 Elizabeth St., Philadelphia, Penn.

RADIO SERVICE MAN would like to make connection with store or factory or take care of radio service work for store on contract basis. 5 years' experience, 3 years outside. Reference: National Radio Institute, Washington, D. C. Louis Schudde, 155 Meserole St., Brooklyn, N. Y.

RADIO REPAIR AND SERVICE MAN. Age, 19 years. High school graduate. Course in Radio and Television Institute, Chicago. Would consider radio position of any kind, anywhere in U. S. Willing to start at reasonable salary, with chance of promotion. Lloyd B. Phillips, R. F. D. No. 2, New Bethlehem, Pa.

CERTIFIED RADIOTRICIAN. Also high school graduate and at present C. R. E. I. student. Can furnish satisfactory references as to character and ability. Address: H. F. Goodrich, 2020 Seminary St., Dubuque, Iowa.

INVENTIVELY INCLINED, and have diploma from Radio Training Association of America; would like to get in touch with radio factory with high-class laboratory. Former student in Electrical & Mechanical College of University of Kentucky. P. B. Kehoe, 2100 Lee Street, Fort Myers, Florida.

GRADUATE NATIONAL RADIO INSTITUTE, experience with public address systems, short wave radio, and general servicing. Age, 20 years. Locate anywhere. B. H. Love, Valley Center, Kansas.

RADIO COLLEGE STUDENT, age 23 years, married. Understands theoretical and practical radio, experienced in servicing. Desires steady position. Robert L. Smith, Seat Pleasant, Md.

NATIONAL RADIO INSTITUTE GRADUATE, two years' High School; age 20; experience in radio servicing, selling, building, and repairing. Fred J. Kellish, 452 Court St., Elizabeth, N. J.

MEMBER OF INSTITUTE RADIO ENGINEERS, 30 years of age. Many years varied experience as asst.-Chief Engineer, Development, Technical, and Apparatus and Research Engineer with reliable firms. For past two years member of technical staff of Engineering Dept. of Arcturus Radio Tube Co. Business and personal references of the highest order. Gilbert Emerson Maul, 651 Lincoln Ave., Mountain Station, Essex County, N. J. Phone: Nassau 4-6845M.

An AC Bridge Circuit

Inductance and Capacity Measurements Made

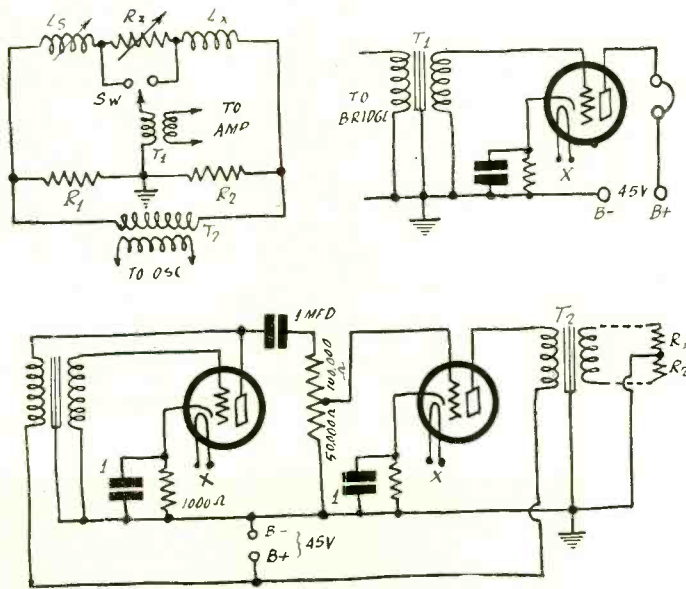

FIG. 1

The circuit of an AC bridge for measuring inductance. The source of alternating electromotive force is an audio frequency oscillator and the detector of balance is a headset or an amplifier.

FIG. 2

The circuit of an oscillator suitable for use with the bridge in Fig. 1. An extra tube is used to avoid special parts.

FIG. 3

The circuit of a one-tube amplifier which may be used in the bridge for indicating balance.

INDUCTANCES may be measured with bridges in the same manner as resistances provided that a suitable source of alternating electro-motive force and a suitable balance indicator be provided.

The alternating electromotive force, which takes the place of the battery in a DC bridge, may be either modulated or unmodulated, depending on the method used for indicating balance. If an audible frequency be used the simplest indicator is a headset, which may be preceded by an amplifier or it may be connected directly in the bridge. If a modulated radio frequency electromotive force be used the indicator may also be a headset but in this case it is necessary to interpose a detector of some kind between the bridge and the indicator, and an amplifier, too, if the bridge balance indicator is to be sensitive.

As the inductance and the resistance of coils change with frequency the measurement should be done with the frequency at which the coil measured is to be used. Unfortunately, when high frequencies are used capacity effects enter which change the balance, and the error in the result may be greater than if an audio frequency were used. Therefore an audio frequency is recommended. The change in the inductance will not be great. The change in the resistance, however, will be large, but this is of little importance when the inductance is wanted.

Diagram of Bridge

In Fig. 1 is a typical bridge circuit connected for measuring the value of inductance L_x in terms of the standard inductance L_s and the resistances R_1 and R_2 . T_1 is the coupling transformer between the bridge, and the balance indicator and T_2 is a transformer between the bridge circuit and the source of alternating electromotive force. R_3 is an adjustable resistance variable in steps of one ohm. A three dial decade box having ten units, ten tens, and ten hundreds is suitable. T_1 may be an ordinary audio frequency transformer with the primary connected in the bridge and the secondary in the grid circuit of an amplifier tube. The secondary of T_2 may be an extra winding on a transformer used in an oscillating circuit.

A switch Sw is arranged so that the resistance R_3 may be connected in series either with the standard or the unknown inductance, depending on which has the lower resistance. A bridge of this kind cannot be balanced completely without separately balancing the resistances and the inductances.

R_1 and R_2 should be known, non-inductive resistances. They

may have different values but preferably they should be exactly equal, say 1,000 ohms each.

Conditions for Balance

Suppose the bridge has been balanced so that no alternating current flows through the primary of T_1 , as indicated by no signal in the headset or other detector. Also call the impedance of the arm containing L_s , Z_s and that containing L_x , Z_x . Let the current through Z_s and Z_x be I_1 and through R_1 and R_2 , I_2 . The voltage drop in Z_s is the same as that in R_1 and the drop in Z_x is equal to that in R_2 . Hence we have $Z_s I_1 = R_1 I_2$ and $Z_x I_1 = R_2 I_2$. Divide one of these equations, member for member, by the other. We get $Z_s/Z_x = R_1/R_2$, which is the condition for balance. If now, R_1 and R_2 are equal we have the simple condition that Z_s equals Z_x .

But the impedances are complex, containing both resistance and reactance. For complete balance the resistances and the reactances must be equal independently. Thus if the resistance part of Z_s and Z_x are, respectively, R_s and R_x , we have the condition that $R_s = R_x$. Likewise, if the reactances of Z_s and Z_x are, respectively, X_s and X_x , we have $X_s = X_x$. But the reactances are proportional to the inductances so that we also have $L_s = L_x$. Thus with one balance we get both the resistances and the inductances.

In case the resistances R_1 and R_2 are not equal the Standard inductance or the standard resistance must be multiplied by the ratio R_2/R_1 to get the proper value of L_x or R_x . It is not recommended that these resistances be made unequal unless it is necessary in order to measure a smaller or larger unknown than the range covered by the standard, and even then it would be better to get a different standard so that the two resistances could be kept equal.

Suppose it is not possible to get a balance when resistance of R_3 is in series with the standard, where it is in the drawing. It is then necessary to switch R_3 to the arm and put it in series with the unknown. The equation for the resistance takes into account the resistance R_3 and its value at balance is the amount by which the resistance of one inductance exceeds that of the other. In order to get the resistance of the unknown it is necessary also to know the resistance of the standard. However, if the inductance only is wanted the values of the resistances may be ignored, once the balance has been obtained.

Absolute silence in the headset should not be expected even when the inductances and the resistances have been balanced because there are couplings between the detector and the oscillator which cannot easily be removed. To obtain silence it is usually necessary to shield the oscillator and the detector circuits separately and to use independent and shielded power supplies for the tubes. But a very low minimum sound can be obtained without much difficulty even when there is no shielding.

The Oscillator

In Fig. 2 is an oscillator and amplifier circuit which is suitable for supplying the alternating electromotive force. T_3 may be any audio frequency transformer such as those used in audio amplifiers, and T_2 may be any audio output transformer. Two tubes are used in this circuit so that no special parts are needed, that is, no parts not used in radio receivers. A single tube could be used if T_3 had a third winding for connecting across R_1 and R_2 in Fig. 1.

Fig. 3 shows a one tube amplifier for detecting balance. Transformer T_1 in this circuit is the same as T_1 in Fig. 1. Note that the cores and cases of all the transformers are ground in all these circuits.

The frequency at which the first tube in Fig. 2 oscillates is mainly determined by the distributed capacity in the secondary of transformer T_3 . If this is a high grade audio transformer it is likely the frequency will be very low, but it will not be too low. If the transformer is a cheap one, the frequency may be high. If it is too high it is only necessary to connect a condenser across the secondary, that is, from the grid of the oscillator tube to ground. The larger this condenser the lower will the frequency be. Convenient frequencies are those between 500 and 2,000 cycles.

Through the symbol of the standard inductance in Fig. 1 is an arrow, which indicates that inductance should be continuously variable. Such inductances are called inductometers, and are simply variometers calibrated in inductance units, usually in millihenries. One commercial variometer has a total range from 0.185 to 5.73 millihenries divided into two, one from 0.185 to 1.42 millihenries when the rotor and stator coils are connected in parallel and the other from 0.745 to 5.73 millihenries when they are connected in series. The dial is divided into 100 divisions and the inductance on either range is very nearly proportional to the scale. For example, at 40 on the scale the inductance when the coils are in parallel would be 0.679 millihenries and when in series, 2.739 millihenries.

The DX-4 Converter

Circuit with Parallel Heaters and B Choke

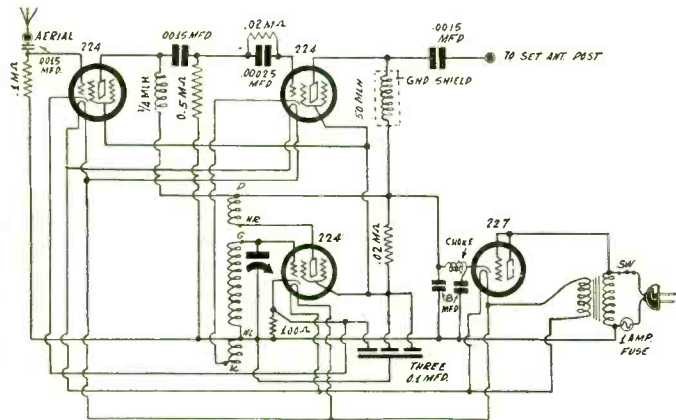

Fig. 1

The circuit with parallel heaters and a choke in the B supply.

[The DX-4 All-Wave Converter was shown last week, issue of March 14th, with heaters in series and without a choke in the rectifier circuit. This week parallel connection of heaters is shown, and choke included. Editor.]

THE inclusion of a B supply in a converter is economical and convenient, besides giving better assurance of real fine results. The rectifier need not be anything elaborate, just a 227 tube hooked up as diagrammed in Fig. 1.

If the filter capacities used are as high as 8 mfd. each, then a B supply choke is not essential, although one may be included with a somewhat steadier DC voltage resulting. The inductance of the choke is not important, nor its current-carrying capacity, since the requirements here are smaller than those encountered in almost all other radio uses. If a choke is included, the capacities used for filtration may be less than those specified.

When the DX-4 Converter is used, there are only two connections to make: aerial is removed from the receiver and connected instead to the antenna post of the converter; then a wire is connected from the output post of the converter to the vacated antenna post of the set. With tubes inserted in the converter, and the AC cable connected to the line, and your receiver functioning, you are ready to tune in the short waves.

Intermediate Frequency Choice

It is well to use as intermediate frequency a frequency either above or below the broadcast band. The highest broadcast frequency is 1,500 kc, and if this comes in before the dial is turned to extreme position, you know your set tunes higher than 1,500 kc, so work in that region. The reason is that you must be clear of the broadcast band to be sure that you will not suffer interference from broadcasting station on the intermediate frequency, or some frequency close to it.

Another point is that coils are designed for all-wave work on the basis of a high intermediate frequency, so that if you use the other extreme, lowest broadcast frequency, you can not tune in the entire broadcast band when working the converter for this purpose.

However, some sets are more sensitive at the lower frequency extreme, and it is advisable under such circumstances to use that frequency, since tuning in broadcasts by conversion does not accomplish any more than the receiver itself does, in that region. The principal object of the converter is to bring in short waves, and this it does, to an extent depending on the selectivity and the sensitivity of your receiver.

Case of Superheterodyne's

One source of difficulty may be working the converter with a set that is itself a superheterodyne. The reason probably is that many such receivers have a low value of resistance as the antenna load, say, 2,000 ohms. But if you have a super, and the converter does not give complete satisfaction when you connect as previously directed, then simply connect the output of the converter instead to the primary of the first intermediate transformer. This is done easily by removing the first detector tube from the super, and putting the bare wire of the converter's output lead into the plate spring of the super's first detector socket. This will prevent reception of broadcast frequencies, of course, but the super itself will attend to that; while the short-wave mixer, that is, the converter, will attend even more effectively to the short waves.

That is about all the dope that one needs about connections to any kind of set.

When an independent B voltage is required, if it is satisfactorily

furnished, the results will be just as good as with the converter with B supply built in, but it has been found that users not familiar with radio will get wrong voltages, or reduce the voltage in their sets unintentionally by drawing converter B current through a series resistor, or otherwise run into voltage or connection troubles that might make them feel that these converters are just a racket.

Effective and Efficient

Far from that, however. The converters are effective and efficient, even though a wire may break in shipment once in a while, and a man connect an intended B plus lead to ground, and a ground lead to B plus, and wonder why two European stations did not come in at once at the same dial setting.

The conversion principle is a sound one and consists simply of constituting the converter and your receiver into a superheterodyne from short-wave reception particularly, where the converter is the mixer or frequency changer, and the set is the intermediate amplifier, second detector and audio channel.

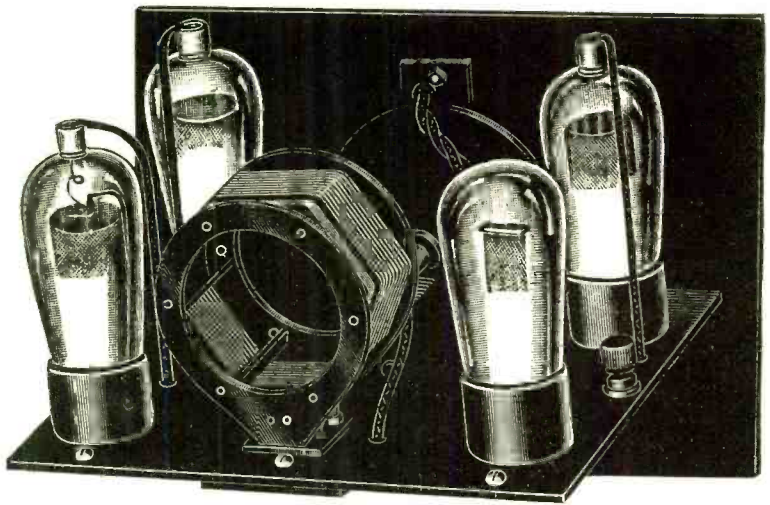

FIG. 2

Rear view of the DX-4 all-wave converter. The precision plug-in coils fit into a five-prong tube socket, while the tubes are symmetrically arranged along the sides. The condenser used (not visible) is a Hammarlund junior midline, of .0002 mfd. capacity.

SUBSCRIBE NOW!

RADIO WORLD, 145 West 45th St., New York City. Enclosed please find my remittance for subscription for RADIO WORLD, one copy each week for specified period:

- \$10.00 for two years, 104 issues.
- \$6 for one year, 52 issues.
- \$3 for six months, 26 issues.
- \$1.50 for three months, 13 issues.
- This is a renewal of an existing mail subscription (Check off if true).

Your name

Address

City

Calibration of Short-Wave

By Henry B.

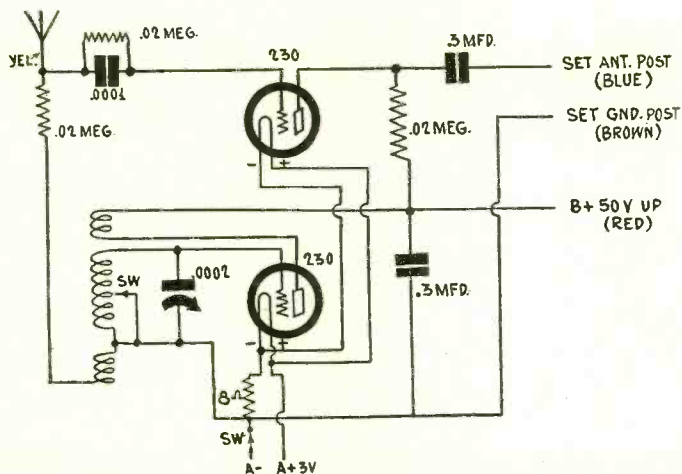
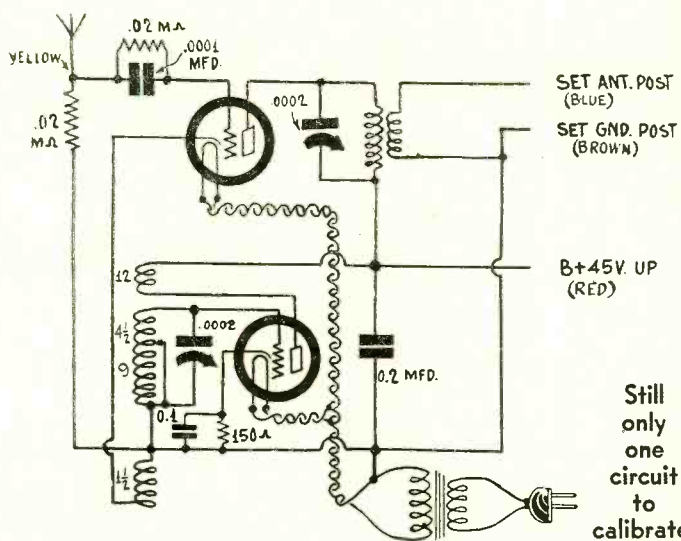

Fig. 1

The simplest converter. Only the oscillator circuit is tuned, so calibration is restricted to this.



Still only one circuit to calibrate

IN a short-wave receiver of the tuned radio frequency or regenerative type, the wave band covered by particular plug-in coils may be ascertained simply by tuning in, and listening to the frequency announcement. This is a long job, since a great deal of talking goes on before any mention is made of frequency, in fact, some stations don't mention the frequency unless signing on or off. Another point is that considerable code is heard, and if one does not read code, of course he gets no calibration advantage from that reception.

Standard frequencies are transmitted by the Federal Government and by stations associated with the American Radio Relay League, but unless the desire to calibrate runs abnormally high, or there is some commercial aspect involved, one is not likely to be tuning in for these standard signals when they are on the air.

Beat With Harmonics

If the circuit is regenerative, or if it is a super-superheterodyne mixer, it is impossible to use broadcasting stations to ascertain the frequency. The method is to strike a beat note with harmonics of broadcast frequencies.

In general, some idea of the wavelength or frequency of short wave tuners is at hand. The coverage may not be known, but where a few stations of known or ascertainable frequency come in, is of considerable help, as it gives one the important clue as to the general frequency region in which he is working. Stations like the Youngstown, O., police transmitter, and the short-wave adjuncts of WENR, KDKA and WGY are familiar examples.

Suppose, therefore, that you use a particular coil and condenser, and that a station on 50 meters comes in near the maximum setting of the condenser. If the frequency method of expression is used, and it is preferable, then the lowest frequency is somewhat less than 6,000 kc, and the beat note comparison may be checked against this known datum for determining the general location of other frequencies.

A broadcasting station around 500 meters, or 250 meters, may be selected. The frequency of the station is known or ascertainable. When an oscillating or regenerating circuit is tuned in to the short waves, there will be a beat note with broadcast stations harmonics, here the fifth and the tenth harmonics of the two broadcast frequencies.

Choose Frequency Wisely

So we may obtain either the absolute value in frequency for maximum setting of the short-wave tuning condenser, or the absolute value for some frequency a little higher, since we are dependent on broadcasting frequencies, and these are 10 kc apart, giving us 100 kc jumps, if we are working the tenth harmonic.

At the opposite end of the short-wave tuning spectrum the same check-up may be made, but it is important to try for a harmonic of the highest broadcast frequency that produces a strong signal and yet represents a frequency that enables us to tune the short-wave outfit at least almost to its highest frequency extreme.

The uncertainty suggested in the foregoing, about not knowing exactly what region one is working in, arises naturally from the fact that one does not know, from hearing a beat note whether it is due to mixing of the short-wave frequency with the third, fifth, tenth, etc., harmonic of the broadcast carrier's fundamental. There

is no easy way to tell by listening, or even by simple measurement, even though the harmonics have a certain definite intensity relationship to the fundamental. One drawback is that we do not

Modern Sets R

PAUL KLUGH, of the Zenith Corporation, says that in 1923 his interest started in radio. He sat up nights with phones clamped to his ears and tried to find sounds which resembled music.

"The crashes of static threatened rupturing my ear drums," he said. "But, I persisted and was rewarded, upon occasion by an announcement from a distant station. The mystery of sound coming without wires intrigued all of us.

"Then chain programs started. For the last four years I have not tuned in distance until last spring, when I again tried for distance. The result was that all of the old lure of distance has come back.

Hears All Channels

"For the past year I have used the 95 wave channels available for Canada, United States, Mexico and Cuba for my entertainment with the same zest as formerly. It is a thrill to tune in California, from my Chicago home, with volume sufficient to be heard across the street or to use room volume on KFI without a disturbing noise level.

"I find it frequently a better show to hear a small distant South-

Layout for Amplifier

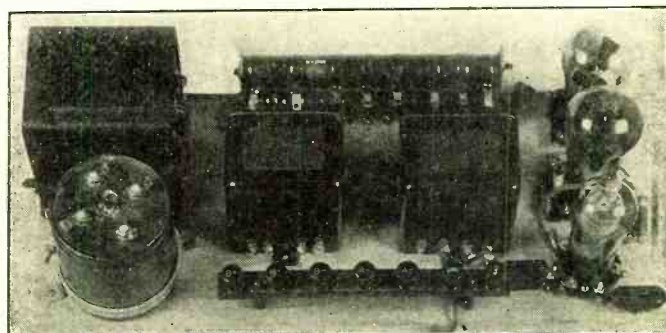

A two-stage resistance coupled audio amplifier may be built according to the constructional plan revealed by the illustration. The third tube is the 280 rectifier. Note that there is no crowding of parts.

Receivers and Converters

Herman

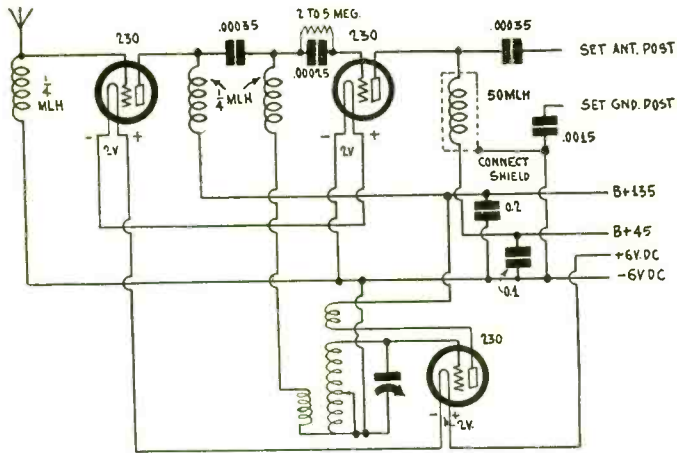

Fig. 3

This short-wave converter for battery operation, using 230 tubes, omitting plug-in coils and using a wave switch.

know the intensity of the fundamental, much less that of the harmonics, in absolute values.

However, when one registers a few points, after having been

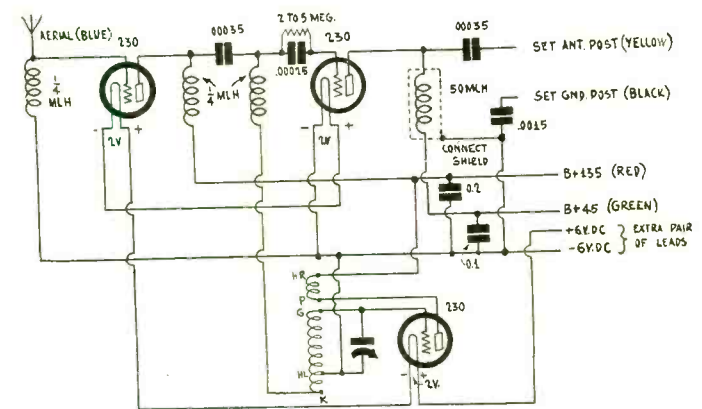

Fig. 4

Plug-in coils are coils in this model, which is otherwise the same same as the one shown in Fig. 3.

guided either by direct reception of short waves, hearing the frequencies thereof given, or by general data on frequency band spanning, associated with certain maximum and minimum capacities of the tuning condenser and a given number of turns of wire on a specified diameter, and these data are reduced to a curve on plotting paper, the curve will take a certain shape.

Calibration of Dial

Doubts may be resolved easily, as the wrong assumptions (e. g., that one is tuning the sixth harmonic, whereas it is the fifth) will baffle one in any one attempting to locate the point on the curve's general contour, as the point will be away off the main road. So, with a fair start, and by association, one may register the correct points all along the line, and plot one's own curve for the short-wave tuning.

In fact, one may calibrate the dial, so that numerical settings represent certain frequencies, and keep a record of this, so that one has what one should have for proper short-wave work, a calibrated receiver. That ends a lot of fishing and hunting and yet produces a bigger "bag."

In the instance of the superheterodyne method of reception, such as used in short-wave converters, the frequency to which the oscillator is tuned is not the frequency of the short-wave station to be received at that setting, but is a frequency that differs from the received carrier frequency by the amount of the intermediate frequency. All that the intermediate frequency consists of is the frequency to which the broadcast receiver or intermediate channel is tuned, which frequency you know.

It will be found, where only one condenser is used for tuning (which is in the oscillator circuit), that some stations, particularly strong ones, come in directly at two points on the dial, but this is not true of beating. Therefore, if one is using the beat method of reception for calibration, the dial settings of the short-wave tuning device are not indicative of the harmonic of the broadcast frequency used for tuning high frequency, but the harmonic of the broadcast frequency used for oscillation. The point is that the oscillator frequency will be different than the frequency to be received, but we know what the difference is. It is the intermediate frequency.

Solution of Problem

Yet by the best method we can solve the problem. Suppose we tune the oscillator. We establish a beat with a harmonic of a known frequency, say, 600 kc. We know that the oscillator represents a definite harmonic when producing a beat, for we have had a general idea, obtained as previously outlined, of the frequency region in which the oscillator is functioning, say, 1,800 kc., the third harmonic. We know, therefore, what the oscillator frequency is, and what the dial setting is for that frequency. But the signal frequency will differ therefrom by the intermediate frequency.

Why not draw a curve, showing the oscillator frequency range? That is not hard at all. A piece of plotting paper and half a dozen or more reference points give us a start, and if we desire we may try for twenty points. We will not experience repeat tuning when we beat, but we will have the shape of the curve. Knowing the intermediate frequency, we know that, if we are to rely on using the higher oscillator setting, as is preferable, the tuning curve will be higher by the intermediate frequency. Since the plotting paper may be made representative of frequency, if the intermediate frequency is 1,500 kc we can draw a curve 1,500 kc removed from the other, and we have our calibration as desired.

evive DX Thrill

ern station selling eye-wash to the hill folks than a jazz band on a chain. And to hear a little station in the Northern Woods announce that the Postmaster is missing his mottled gray mare is worth the price of admission to a good theatre.

"Then take the extemporaneous political speaker on a small station. He speaks freely and from the heart, which is vastly different from the highly polished and carefully edited chain presentations.

A Jibe From Mexico

"How about a Mexican station with an English announcer telling of the warmth and personal liberty found in his country, while we are shivering up north, phoning for more steam and wondering about some of Mr. Volstead's ideas.

"If you want to know what the Western people think of Boulder Dam, you will get it from a station out there and it will be a far more intimate picture than you will get on a chain. I'm not talking against chains. They give us the finest entertainment in the world and, of course, come first in interest. I'm talking about a diversification of entertainment."

The new DX fever is highly contagious.

Smaller Coils Being Used

Many of the recent radio models utilize very small radio frequency coils. Formerly, the best practice was considered to be a coil about 3 inches in diameter, wound with fairly heavy wire. This resulted in low resistance and sharp tuning.

A large coil, however, has a magnetic field which extends some distance from the coil. If metallic objects are nearby, the characteristics of the coil are affected unfavorably. Accordingly, in the modern set, which for reasons of cost and compactness must be reduced in size, the coils are being made smaller and smaller. Many sets use coils as small as one inch in diameter.

Another consideration, too, is the desire for avoiding over-selectivity, due to multiple tuned circuits. A small coil with small wire avoids over-sharpness, but with a succession of four amplifying circuits, the total effect is that of good selectivity but without undue selectivity.

The home radio experimenter will still find plenty of use for the regular 3-inch size, wound with No. 22 to 24 insulated wire, but in the manufactured product, a larger number of smaller size coils may be used with good practicable results.

A tuner made up of many moderately selective circuits adjusted to the same frequency, the effective selectivity and the resulting quality are better than when a small number of highly selective circuits are used. This is true even if the product of the selectivities in the two cases is the same, the selectivity being defined as the inductive reactance at resonance divided by the resistance.

Balancing a Mixer With

By Herman

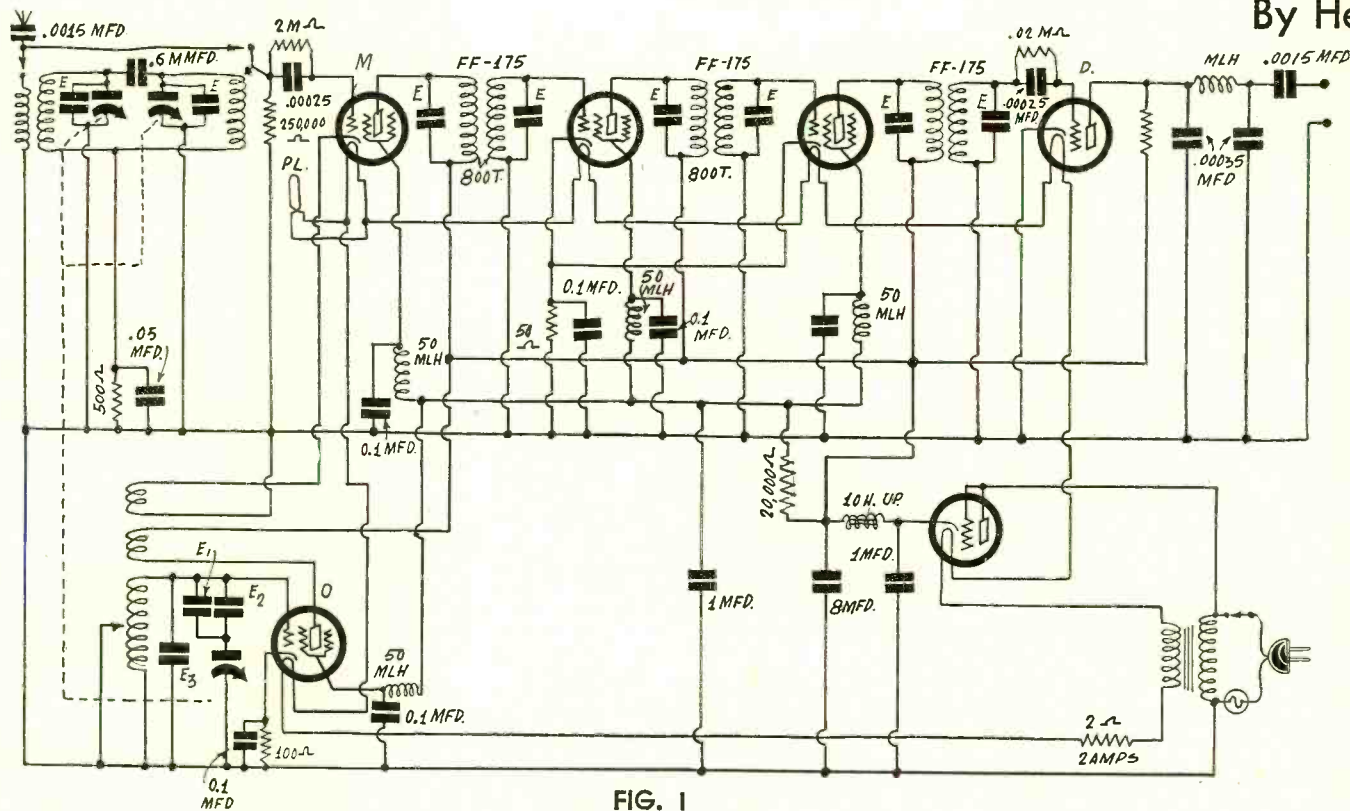

FIG. 1

A five-tube circuit, with rectifier, comprising a totally self-operated superheterodyne tuner. How to balance the mixer in a new way is explained in the test.

IN the construction of a superheterodyne, where single control of tuning is to be included, the principal consideration is attainment of proper proportion of inductance and capacity in the oscillator's tuned circuit, since if this work is not done accurately, results will be very poor, no matter what precision attaches to the remainder of the task.

The diagram, Fig. 1, shows a band pass filter input to the modulator tube (upper left), while the oscillator circuit is depicted below. Note that a three-gang condenser is used, one section tuning the secondary of the antenna coil, another section the impedance coil in the grid circuit of the modulator, and the third section, with certain additional capacities, the oscillator secondary.

It is the third section that we will discuss particularly.

How to constitute the oscillator circuit depends to a considerable extent on the intermediate frequency used. The three transformers between tubes, with condenser across primary and secondary, establish the intermediate frequency. Let us assume that it is 175 kc, as that is the most popular intermediate fre-

quency to-day, being used in most commercial superheterodyne receivers, and being chosen for its relative freedom from interference by direct pickup by the intermediate amplifier.

The dash line to the condensers' rotor indicates that these condensers are ganged. The intermediate frequency is 175 kc, and as we shall choose the oscillator frequency that is higher than the broadcast frequency by that amount, we may use the same inductance for the oscillator secondary as for the antenna secondary and the impedance coil, but reduce the oscillator tuning capacity.

A series condenser will accomplish this. It has to be placed between the stator of the oscillator tuning condenser and the grid of the oscillator tube, because the rotor is grounded in the modulator circuit, hence remains so in the oscillator circuit, since there is only one possible connection for a common rotor.

This series capacity is represented by E1 and E2. Since adjustment has to be made, one of these capacities might be fixed and the other variable, but whatever the distribution, the result is that only one effective series capacity remains. In the present instance we use two 100 mmfd. Hammarlund trimming condensers or equalizers, since one may be used at minimum setting, and the other varied, or any other combination of them tried. Then there is another capacity, E3, of the same kind, across the total tuned circuit, grid to ground, for trimming the total.

Because the intermediate frequency is of vital importance it might be assumed necessary to have the intermediate amplifier before the the circuit can be adjusted, but this is not so. Coils are obtainable that are tuned to 175 kc, so the intermediate frequency may be selected mentally, and the mixer given preliminary balance without final check-up of alignment.

Even if everything is built, virtually no signals may be received, due merely to the lack of proper adjustment of the oscillator. Several expensive devices are on the market that enable making the adjustment properly, but we shall now proceed to describe a preliminary method that has proved easy and beneficial.

With antenna and ground connected as shown, loosely couple a small winding to the impedance coil and connect one side to the antenna post of another receiver of any kind, even a one-tube regenerative set you may build for the purpose. Connect a wire from the ground post of the mixer to the ground post of the other set. Now you are using the band pass filter as a pretuner for the other, and by tuning in the broadcasting stations with the set, and using the pretuner for notation of greatest volume, the calibration in frequencies may be obtained for the band pass filter. The broadcast station frequencies are known or obtainable.

It is preferable to transfer the readings to plotting paper, so as

LIST OF PARTS

Coils

- Three radio frequency coils for .0005 mfd.
- One series filament transformer
- One B supply choke coil, junior model
- One 50 mlh. radio frequency choke coil

Condensers

- One three-gang .0005 mfd. condenser
- Three 100 mmfd. Hammarlund equalizers (E)
- Three .00035 mfd. fixed condensers
- Four blocks, each containing three separate 0.1 mfd. condensers
- Two 8 mfd. dry electrolytic condensers
- One .00025 mfd. grid condenser
- One 0.6 mmfd. Hammarlund band pass coupling condenser

Resistors

- One 500 ohm flexible band pass resistor
- One 100 ohm flexible biasing resistor
- Three 0.1 meg. pigtail resistors
- One 0.25 meg. pigtail resistor Three 0.5 meg. pigtail resistors
- One 2,000 ohm flexible biasing resistor
- One 250,000 ohm potentiometer
- Two .02 meg. (20,000 ohm) pigtail resistors

Other Parts

- One 10 3/4 x 6 1/2 x 2 inch metal subpanel, with six socket holes
- Six UY sockets One vernier dial
- One dozen each 6/32 machine screws and nuts
- One roll of hookup wire One AC switch, shaft type

out Tubes or Amplifier

Bernard

to have a curve, which may be run after you have established ten points or more, being particular to get the extreme points, as far as practical. The curve will follow a general contour, and any undetermined frequencies can be approximated by completing the curve on the revealed basis of its contour.

What you will write down on a piece of paper is something like this: WNYC, 95, 570; WEA, 80, 660; WOR, 70, 710; WJZ, 60, 660, etc., where the numbers after the call letters represent dial settings and the numbers after the dial settings represent the frequencies. Transfer of this data to plotting paper and formation of the curve is easy.

Now we know where every frequency will come in on the modulator tuning circuit. Our problem is to establish the same numerical dial settings for the oscillator, although the oscillator will tune for the respective settings to frequencies 175 kc higher than those of the broadcasting stations.

It is a general practice to coincide two remote points of the oscillator tuning system with those of the modulator tuning system. One may select the extremes of the broadcast spectrum, 1,500 kc and 550 kc, or frequencies close by. Suppose we select 1,400 kc and 700 kc, as these are respectively the eighth and fourth harmonics of the intermediate frequency, in fact, the only harmonics of the intermediate frequency that fall in the broadcast band.

By consulting the curve taken for the modulator tuning we know what the oscillator dial settings must be for supplying the intermediate frequency, in conjunction with the modulator, since the settings are to be the same for both.

Disconnect the antenna from the band pass filter input, and connect it instead to the oscillator grid through a small fixed condenser (of .0001 mfd. capacity or thereabouts, using a trimmer from the modulator circuit if necessary). Set the dial of the test receiver to 885 kc, which is 175 kc higher than the chosen lower point of 710 kc. Set the oscillator dial at the same numerical setting as the modulator would have for 700 kc. Adjust the condensers E1 and E2 until the response is loudest in the receiver. The oscillator is now established at a frequency of 175 kc higher than that of the frequency of the station desired to be received later at that dial setting, that is, both modulator and oscillator tuning are unified for reception of that station's frequency.

Now try the same system at the other extreme, 1,400 kc, and the setting will be established for this, too. It may be found that the oscillator reaches 1,400 kc not at 8 on the dial, or thereabouts, as was expected, but at 20, in other words, one setting, already established, throws other far off. But not incurably so. This situation simply means that the condenser E3 has not been set at sufficiently high capacity. Also, the opposite condition, that 1,575 kc could not be reached, as the circuit would tune only to 1,450 kc, would mean that the capacity used for E3 is too large.

Two Points Enough to Tie Down

By trial and test the two settings of the oscillator may be thus established. After the two points are "tied down" the rest of the tuning may be disregarded, as to establish further precise points would require specially shaped condenser plates for the oscillator or other devices not commercially practical.

Now the circuit may be established as shown in Fig. 1, and there is certainty of reception. Lining up has not been accomplished, however. There may be slight discrepancies, and these may be taken up by adjustment when the tuner is functioning. The wire used in hooking up, and the tubes themselves, will change the situation slightly, and such contingencies may be taken care of in the final adjustment.

The same causes affect the intermediate frequency amplifier. In testing it is practical to listen to the loudspeaker and adjust for loudest response. This includes very slight adjustment of the trimming or tuning capacities across the primaries and secondaries of the intermediate coils. It will be found that the setting of the condensers across the primaries is the more critical. Only make tiny changes in capacity setting, a small fraction of a turn. If practical, use a meter in an RF plate circuit for minimum deflection or, in a power detector plate circuit, for maximum deflection.

The foregoing method relies on broadcasting stations for the selection of the frequencies for tying down the two points. You may choose any two stations that are on the air at the same time, and within loud reception range of the test receiver, and suitably remote in frequency.

As a check-up on the intermediate frequency, if you will make the intermediate amplifier alone oscillate, and place it near a test receiver, you may adjust the intermediates for loudest squeal with the signal of a station on 700 kc or 1,400 kc, or use both frequencies, if possible, for checkup.

In the foregoing mention was made of tuning for loudest response. The band pass filter will afford wave trap effect at one setting, loud signal just a trifle to one side and much louder

signal a trifle to the other side. This is due to the double bump in the tuning curve. Usually, the increased volume is greater on the higher capacity side, so use this (if it checks up) to establish the desired resonance point. Do not use the "silent setting."

If the same situation presents itself in the oscillator test, make the same choice.

There need be no tubes or voltages for the balancing as already described.

By having two binding posts for antenna, and by tapping the oscillator secondary, provision may be made for tuning in some short waves, as well. The short-wave range would be from about 35 meters to about 120 meters.

The coil data for use with aluminum shields of about 3 inches diameter, about 3 3/4 inches high, with a .0005 mfd. condenser, are as follows:

Antenna coupler (15-85), wound on 1 3/4 inch diameter natural bakelite tubing, 3 1/2 inches high. Primary, wound in a slot cut into the outside diameter, consists of 15 turns of No. 28 enamel wire; secondary, begun 1/8 inch away from primary, consists of 85 turns of No. 28 enamel wire.

Impedance coil (85) wound with 85 turns of No. 28 wire on same diameter, etc., as foregoing.

Oscillator coil (40-80-6), wound in the same manner as the antenna coupler, except that 40 turns are in the slot, and the wire may be finer, if preferred, while an extra winding, six turns of well insulated wire, say No. 24 cotton covered, also is put in the slot. The tap, if used, is the 20th turn from the primary.

Oscillator Coil Directions

Only the oscillator coil is sensitive to polarity, since the 40-turn winding will produce oscillation when connected one way, but act as a damper on oscillation if connected the other way. However, in winding, no particular observance need be made of this, for when you wire up, should you fail to get oscillation, simply reverse the connections on either the secondary or the tickler, but not on both, of course. That is, if you select the secondary (and it makes no difference which of the two windings you choose) to institute oscillation where none existed, connect to grid the terminal that formerly went to ground, and connect to ground the terminal that formerly went to grid.

The 500 ohm resistor in the band pass filter circuit is shown as affording grid return potential and is in line with circuits of commercial receivers.

The .05 mfd. condenser associated with it consists of a block of three 0.1 mfd. condensers in one case. The common black lead and one red lead (any one) are cut off, and the two remaining red leads are used, comprising two .01 mfd. in series, or .05 mfd. The case itself is not connected to the condensers in the manufacture, so may be grounded.

The circuit has a rectifier built in, using a 227 tube in the special circuit designed and invented by J. E. Anderson and the author.

The values of parts are given on the diagram. The circuit can be built for about \$30, not including tubes. Series connected heaters are shown, but if a 2 1/2-volt secondary transformer is at hand, of 12 ampere rating or higher, that may be used.

RICH MARKET FOR YOUR GOODS! OUT NEXT WEEK! 9th Anniversary Number OF RADIO WORLD

Dated March 28. Published March 25. LAST form closes March 17. Increased distribution. Increased value. Increased sales for advertisers.

	1 Inser.	4 consec. Inser. (ea.) 10%	13 consec. Inser. 12 1/2%	26 consec. Inser. 15%	52 consec. Inser. 20%
1 page	\$150.00	\$135.00	\$131.25	\$127.50	\$120.00
1/2 page	75.00	67.50	65.62	63.75	60.00
1/4 page	50.00	45.00	43.75	42.50	40.00
1/8 page	37.50	33.75	32.81	31.87	30.00
1/16 page	25.00	22.50	21.87	21.25	20.00
1/32 page	18.75	16.87	16.41	15.94	15.00
1 inch	5.00	4.50	4.37	4.25	4.00

Classified advertisements, 7 cents a word; \$1.00 minimum; must be paid in advance.

Advertising Department
Radio World, 145 West 45th St., New York, N. Y.

London's New Exchange Engineer Invents

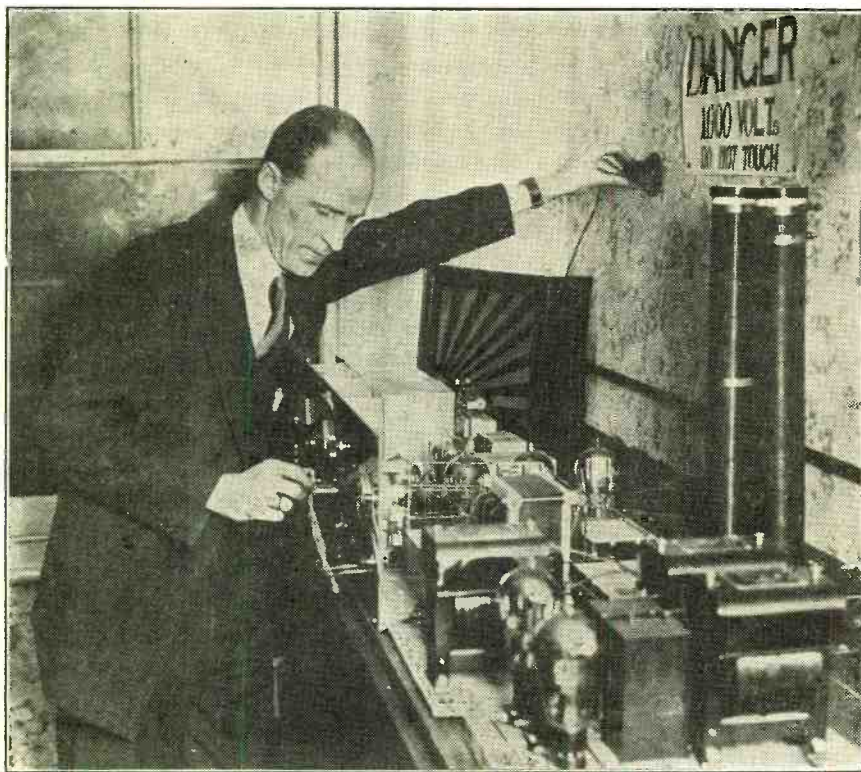

(Acme)

The first exchange, which selects radio programmes from all over the world and delivers them by wired telephone to subscribers in their homes, was recently opened at Bowes Park, London. The subscribers require only a loudspeaker. A charge of one shilling and sixpence is made for a week's service. Over 300 homes have already registered. The relay station is pictured.

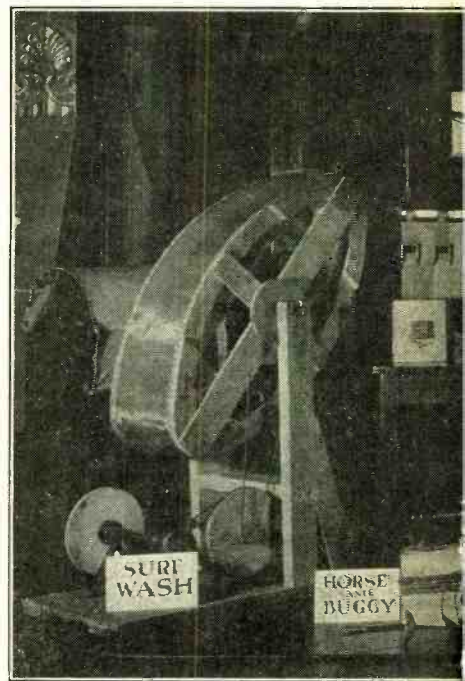

Ray Kelly is Chief Sound Effect Company. It is his job to stimulate an airplane, a haunted house or a battle. The sound effects devices used on the radio include a surf wash, a horse and buggy, and the anchor representing a ship.

R. C. A. in Annual Report Optimistic on Television

In the annual report to stockholders General James G. Harbord, chairman of the board of directors, and David Sarnoff, president, the Radio Corporation of America, announced a program for intensive development and the widest diversification practicable in the various fields of radio communication and the electrical entertainment arts.

The report was the first issued by RCA since its unification plans, consummated during 1930, permitted the integration of all research, engineering, manufacturing and sales activities.

"Developments of the year 1930, which began with from 11,000,000 to 12,000,000 radio sets already in operation in the United States, with vast manufacturing units competing for markets already affected by economic depression, fully justified the planning, effort and investment involved in effecting this union of naturally correlated activities," said the report.

Net Income \$10,366,269 Less

Gross income of the Radio Corporation of America and its wholly-owned subsidiary companies from all sources for the year 1930 was \$137,037,596. The net income of the Corporation for the year was \$5,526,293. Regular dividends on all classes of preferred stock, amounting to \$5,206,000, were paid during the year. No dividends have been paid on the common stock. The net income for the year was

Synchronization Sought by WLBW

Washington.

The Radio Wire Program Corporation of America, operating WLBW, Oil City, Pa., petitioned the Federal Commission to grant authority to construct a new transmitter in Erie, Pa., synchronizing it with the present transmitter at Oil City.

The brief was submitted following a hearing held on the application at which time WEDH, at Erie, offered opposition. WLBW now operates with 1,000 watts day and 500 night on the 1,260-kilocycle channel, and with its synchronization plan, the two transmitters of the one company would be operated on the same frequency with the same power simultaneously, with an accuracy of frequency adjusted to eliminate heterodyne interference, the brief states.

\$320,293 in excess of dividend requirements of the preferred issues. The net income for the year 1930 compared with a net income of 15,892,562 in 1929.

Inventories of all RCA companies at

December 31st amounted to \$28,253,713 and were valued at cost or market, whichever was lower. This figure was approximately \$3,000,000 less than that shown on the balance sheet of December 31, 1929. The inventories at the end of 1930, however, were of a complete manufacturing and selling company, and included raw materials, supplies and work in process as well as finished goods.

"The reduction in earnings, particularly marked during the first half of 1930," the report stated, "was due to the decline in consumer purchasing power as a result of the world-wide economic depression, the consequent readjustment of prices, and the wide-spread liquidation of radio sets forced upon a number of manufacturers by the need for disposing of substantial inventories. Moreover, earnings for the year 1930 were affected by the extraordinary expenditures incident to the year's program of unification, which included the rehabilitation and enlargement of the manufacturing plant at Camden, New Jersey.

Now a Holding Company

Explaining the organization of the Radio Corporation of America the report said:

"For convenience in administering of a business of such diversified character, Radio Corporation of America has become

Machines for Sound Effects WEE, Tiniest Station

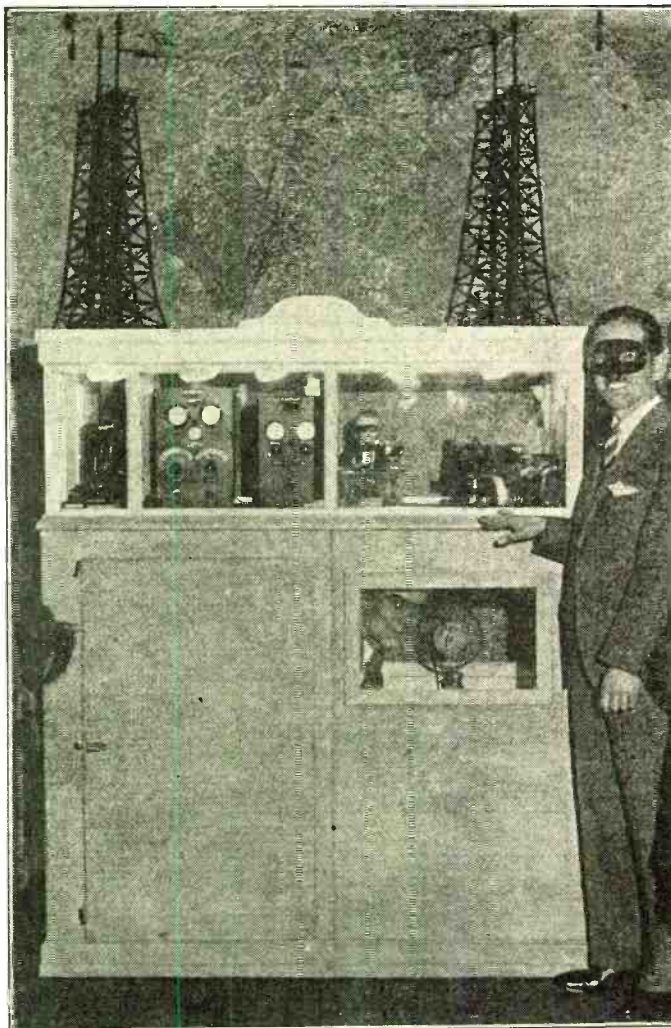
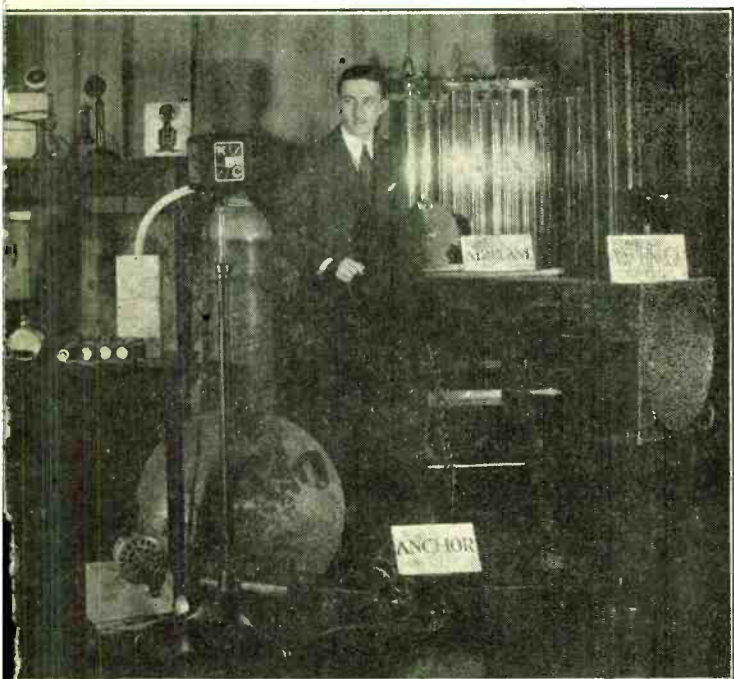

Engineer of the National Broadcasting Company is shown with some of the instruments that make the sound of an ocean, a tri-motored airplane, a road line. He is shown with some of the instruments that make the sound of an ocean, a tri-motored airplane, a road line. He is shown with some of the instruments that make the sound of an ocean, a tri-motored airplane, a road line.

(Acme)

WEE, the world's smallest station, is operated by the Tiny Broadcasting Company, 1,300 kc. The miniature station is accurate in all respects and has a sending range of 200 feet. It operates under its own power on .04 watt.

largely a holding company. It is engaged in coordinating its diversified interests in every field of radio development, in exercising general supervision over financial matters and research activities, in administering patent licenses and the collection of royalties and in protecting the broad legal rights of its various subsidiaries."

"Television has been brought definitely nearer to commercial development by the research and technical progress made by your Corporation during 1930," said the report.

"While television during the past two years has been repeatedly demonstrated by wire and by wireless on a laboratory basis, it has remained the conviction of your own corporation that further research and development must precede the manufacture and sale of television sets on a commercial basis."

"In order that the American public might not be misled by purely experimental equipment and that a service comparable to sound broadcasting should be available in support of the new art, your corporation has devoted its efforts to intensive research into these problems, to the preparation of plant facilities and to the planning of studio arrangements whereby sight transmission could be installed as a separate service of nationwide broadcasting.

What Is Desired for Television

"It is felt that in the practical sense of the term, television must develop to the stage where broadcasting stations will be able to broadcast regularly visual objects in the studio or scenes occurring at other places through remote control."

WILKINS PLANS AIR NARRATIVE FROM ARCTIC

Washington.

The first attempt to rebroadcast direct from the Arctic regions a "running account" of the explorations of any polar expedition will be made by Capt. Sir Hubert Wilkins, northern explorer, this Summer, he told the Federal Radio Commission.

At a conference with Commissioner William D. L. Starbuck, in charge of engineering activities, and Dr. C. B. Jolliffe, chief engineer. Sir Hubert discussed the radio plans of his expedition to be made in a submarine chartered from the United States Shipping Board. Commissioner Starbuck said, following the conference, that Sir Hubert sought advice concerning applications for both high frequency code and rebroadcasting channels to be used by the expedition.

Tests Considered of Value

It was explained orally at the Commission's Engineering Division that

voice transmission from the polar regions never before has been attempted and that the results of the tests planned by the Wilkins expedition would be valuable to the radio art.

It was recalled that the Byrd Antarctic expedition was not equipped with telephone transmitters and that its daily communication with the United States was by code.

The Wilkins expedition, Sir Hubert explained to the Commission officials, is scientific in nature and will study geophysical and meteorological phenomena in the Arctic.

To Use Old Submarine

The submarine, an obsolete naval type, which was turned over to the Shipping Board by the Navy and chartered for use by the expedition, is being reconditioned and is to be equipped with ice boring attachments to permit it to break through the Arctic ice. Sir Hubert explained that when the submarine was on the surface, it was proposed to transmit over the radio telephone transmitter accounts of the expedition's experiences. He said the expedition plans to leave for the North Pole in May, but that it might get away earlier.

Formal applications for the frequencies desired for the expedition will be filed with the Commission in due course, according to "The United States Daily," and radio technicians of the expedition will confer further with the Commission's engineers concerning the arrangement.

Design of Intermediate

By J. E.

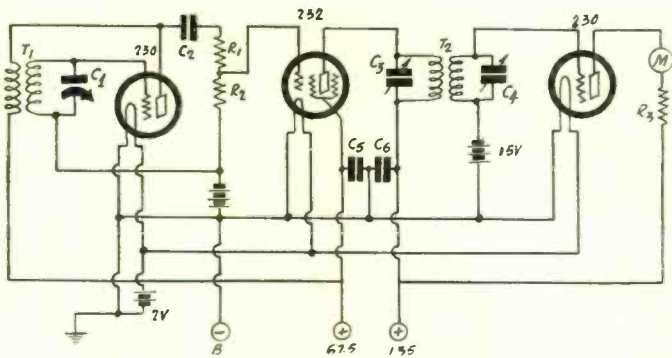

Fig. 1

The circuit of a tester suitable for taking resonance curves on tuned circuits and for studying the effects of coupling. The first tube is an oscillator, the second an amplifier, and the third a vacuum tube voltmeter or rectifier.

WHEN both the primary and the secondary of a radio or intermediate frequency transformer are tuned to the same frequency, should the coupling be loose or close for best all around results? What constitutes close or loose coupling? Does the volume decrease or increase when the coupling is increased? These are some of the questions frequently asked by fans who have read statements about coupling selectivity and sensitivity.

A complete answer to these and related questions would require a book, but the main points can be covered in a brief article. Some will be answered by means of curves and a circuit diagram of a tester by means of which any experimenter can answer them for himself will be given.

In this article we shall be concerned principally with an intermediate frequency transformer tuned to 175 kc in both the primary and the secondary.

The Transformer

The transformer used was of the duolateral type wound with fine silk covered wire with 800 turns of the following dimensions: axial length of the winding, 5/16 inch; inside diameter, 1/2 inch; outside diameter, 13/16 inch. Each winding was tuned with a trimmer condenser having a capacity range of 20-100 mmfd. and connected between a 232 screen grid tube and a 230 tube vacuum tube voltmeter simulating as nearly as possible the conditions under which the transformer is to be used in practice.

Each winding was on a hardwood core one-half inch in diameter which extended 3/16 inch in one direction and 3/8 inch in the other. These dimensions of the core are given because they determined the degree of coupling between the windings.

The test circuit in which the measurements were made is given in Fig. 1. The first tube is an oscillator the frequency of which was adjustable by means of a 100 mmfd. tuning condenser C1 over a fairly wide range about the 175 kc frequency to which the transformer under test was tuned.

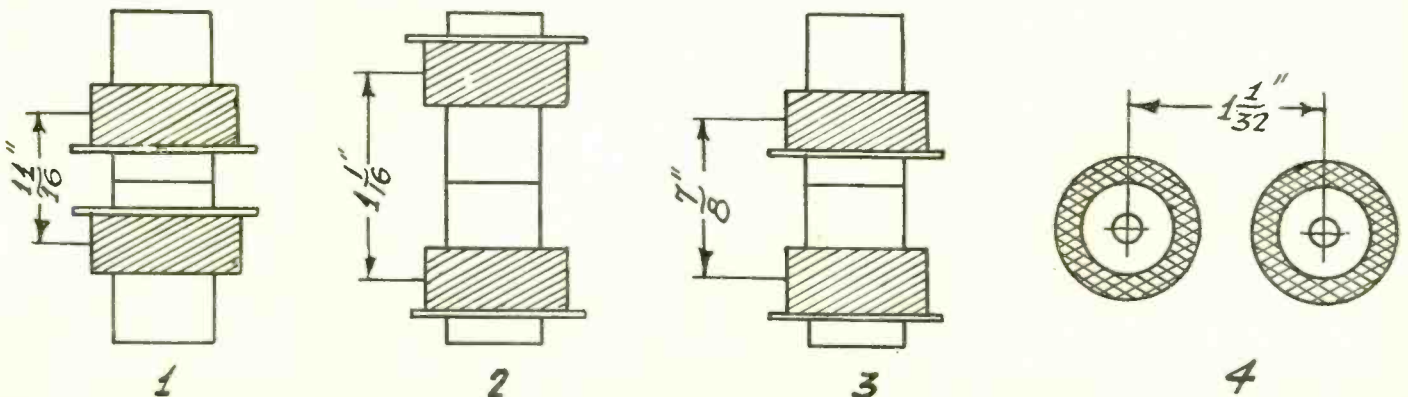

Fig. 2

These diagrams show the different positions in which the 800 turn tuned primary and secondary transformers were tested.

T1 is the oscillator transformer, which was made of two coils just like the coils under test and placed side by side as in position (4) of Fig. 2. The secondary alone of this transformer was tuned by means of the adjustable condenser C1.

A radio frequency amplifier of one 232 screen grid tube was coupled to the oscillator by means of a .00025 mfd. condenser C2 and two 100,000 ohm resistances R1 and R2, the voltage drop across R2 alone being impressed on the screen grid amplifier. The voltage output of the oscillator was divided in this manner to prevent overloading of the screen grid tube and the voltmeter tube. It happened, however, that it made little difference in the output whether the grid of the screen grid tube was connected to the top of R1 or to the junction of the two resistors.

Two resistors offer a means of varying the input to the screen grid tube as required by the voltmeter tube by changing the values of the resistors in the clips holding them. The larger R2 is with respect to R1 the greater the output.

Position of Tested Transformer

T2 is the transformer under test, the two windings of which are tuned with condensers C3 and C4, both of which are of the trimmer type having a maximum capacity of 100 mmfd. Curves were taken on this transformer for different distances between the coils.

The last tube in the circuit, like the oscillator tube, was of the 230 type and was operated as a grid bias detector. The intensity of the input was measured by the deflection on the 0-1 milliammeter M in the plate circuit of this tube. The resistance R3 was of 100,000 ohms and was used to limit the current in the plate circuit to fit the indicator meter used. A considerably greater deflection will be obtained if a .1 mfd. condenser is connected from the plate of the output tube to ground.

The grid bias on the oscillator and on the screen grid tube was held at 3 volts. This was used because it gave maximum output under the other conditions of operation. The same voltage was applied on the plate of the oscillator as on the screen of the amplifier and was 67.5 volts. The plate voltage applied on the screen grid tube and on the output tube was 135 volts, and the grid bias on the output tube was 15 volts. Under these conditions the greatest output, as will be seen from the curves in Fig. 3 was slightly over 0.6 milliamperere.

The filament current was supplied by a fully charged storage battery cell of 2 volts. No ballast resistance was used since the applied voltage was just right for the tubes.

The negative side of the battery was grounded to stabilize the circuit and the two condensers C5 and C6, each of which was of 8 mfd., was used for the same purpose. The voltages for the plates, the screen, and the grids were obtained from dry cell batteries.

Obtaining 175 kc.

The circuit was tuned to 175 kc by utilizing the beat between the fourth harmonic of the oscillator frequency and a broadcast frequency of 700 kc. The test circuit was placed near a sensitive broadcast superheterodyne tuned to 700 kc and then the oscillator condenser C1 was varied until zero beat frequency was obtained. When this had been found the two condensers C3 and C4 were adjusted until the output meter was maximum. C3 was adjusted first until the output was as great as it could be made and then C4 was adjusted similarly.

The adjustment of these condensers changed the oscillator

Coupling Transformers

Anderson

frequency slightly as determined by the change in the beat frequency, but this was remedied by retuning C1 for zero beat and again tuning C3 and C4 for maximum output. During the second adjustment there was only a slight change in the frequency, which did not matter. The object of the experiment was to obtain resonance curves for different degrees of coupling between the coils near the 175 kc frequency, and a deviation of 5, or even 10 kc, made no practical difference. The deviation was actually less.

Close Coupling

At first the coils under test were placed as at (1), Fig. 2, and the deflection on the meter M observed at every fifth division on the scale of the oscillator dial. The data thus obtained plotted into Curve 1, Fig. 3. Note that the centers of the coils were separated 11/16 inch, the closest they could be placed due to the extensions of the wooden cores.

The maximum deflection for this coupling occurred at 43 on the oscillator dial. As the frequency was decreased, or the capacity of C1 was increased, the deflection dropped rapidly, but as the frequency was changed in the opposite direction there was comparatively little change in the deflection. When the condenser was set at zero the deflection was 0.50 milliamperes whereas at 43 it was only 0.636 milliamperes.

It is clear that the coupling in Position 1 is too close for good selectivity. While the output is fairly good it is not sufficient to justify the broad tuning.

When two tuned circuits are too closely coupled there are two points at which the output voltage is maximum. This is not well defined in the upper curve in Fig. 3, for one of the peaks is much lower than the other and the two almost merge. However, there is an indication of the second peak at 10 on the oscillator dial, where it prevents the rapid fall of the combined curve.

Looser Coupling

The second curve in Fig. 3, lowest but one, was obtained when the coils were placed as in (2), Fig. 2. The coils were placed end to end with the longer core projections toward each other. This made the distance between center and center one and 1/16 inches. This yielded excellent selectivity, the curve falling nearly as much and as rapidly on the upper frequency side as on the lower. There is no trace of the double maximum and we may assume that the coupling is less than the critical, which is the coupling at which the double peak just disappears.

For this case the maximum deflection occurs at 33 on the oscillator dial, and at that point the deflection is 0.52 milliamperes. The selectivity is quite satisfactory, especially in view of the fact that in a practical amplifier there would be at least three similar couplers tuned to exactly the same frequency, and that their selectivities would be cumulative.

Medium Coupling

Next the two coils were placed as in (3), Fig. 2, in which the center to center distance between the coils is 7/8 inch. The observations taken on this coupling yielded curve No. 3 in Fig. 3. The selectivity is considerably better than that for the first position but not quite as good as that for the second position. The maximum deflection occurs at 35 on the oscillator dial and it is 0.55 milliamperes, just 0.03 milliamperes more than the deflection at maximum for the lower curve.

On curve No. 3 the double response is just noticeable by the rate at which the curve drops to the left of the peak, where the rate of descent is not so rapid as it is on the lower curve. The coupling represented by Position 3 is closer than the critical but not very far from it. This coupling could be used in a superheterodyne when four equal tuned circuits are used in the intermediate frequency selector. However, the coupling represented in Position 2 is preferable to that represented by Position 3.

Side-by-Side Placement of Coils

In the first three positions of the coils they are concentric, or they are placed end-to-end with their centers on the same line. But the coils may also be coupled by placing them side-by-side with their center lines parallel. This placement is represented by Position 4 in Fig. 2. The distance between the two center lines is 1 1/32 inch, which was the closest they could be placed because of bakelite washers used for mounting the terminals of the coils. The resonance curve taken with this coupling coincided almost exactly with that for Position 2. They

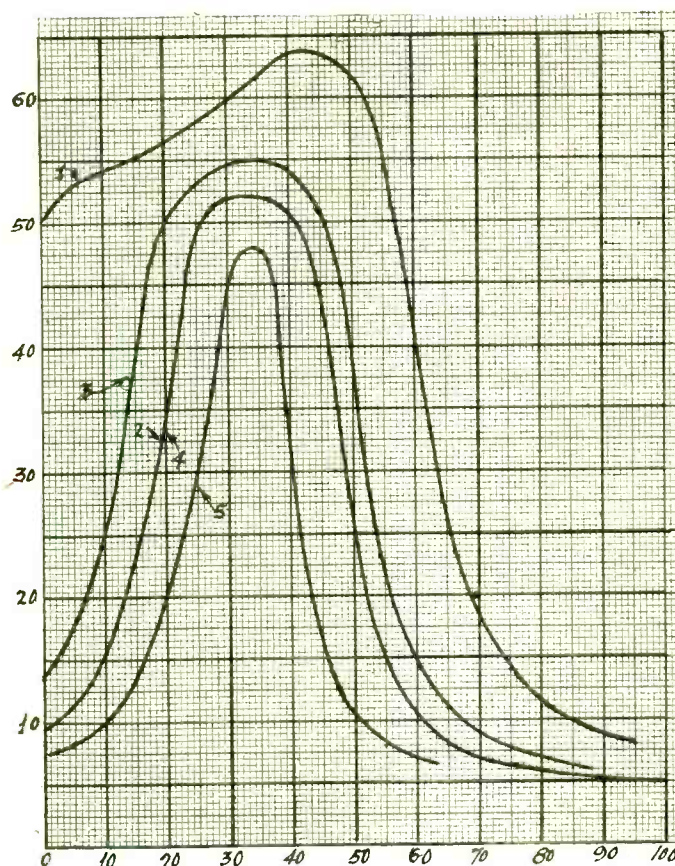

Fig. 3

Resonance curves obtained with the tester in Fig. 1 when the coils were placed in the positions indicated in Fig. 2. The abscissas are dial settings of a 100 mmfd. condenser in the oscillator and the ordinates the deflections in arbitrary units.

were so close to each other that they could not be plotted separately.

Curve 5 was taken on the coils in the same position as Curve 4 but with the distance between the center lines 3/32 inch greater, that is, one and one-eighth inch. This curve shows high selectivity, too high for an amplifier having three or more tuned circuits of this type. Positions 2 and 4 give the best coupling judging by both selectivity and output.

Effect of Metals in Fields

A No. 6 machine screw through the cores of the coils in any of the positions reduced the output at maximum by approximately 0.01 milliamperes. An aluminum shield 2.5 in diameter placed over the coils in Positions 1, 2, and 3 reduced the maximum by about the same amount, but when the same shield was placed over the coils in Positions 4 and 5 the maximum increased by a similar amount. This increase was evidently due to an increase in the coupling by the concentration of the magnetic field.

A sheet of aluminum placed between the coils in Positions 1, 2, and 3 reduced the coupling to zero, as was expected, and this sheet did not have to be more than about one inch square. A metal washer with a hole in the center and about 0.75 inch in diameter reduced the coupling or reduced the maximum reading by a small amount. This was apparently due to a combination of loss and a reduction of the coupling.

Testing an Amplifier

The circuit in Fig. 1 can be used also for taking curves on a complete intermediate frequency amplifier. To make the proper connection it is only necessary to regard the primary of T2 as the primary of the first, or input, transformer of the intermediate frequency amplifier and the secondary of T2 as the secondary of the last IF transformer in the amplifier. There may be many tuned transformers in between as well as several tubes. The selectivity curve obtained on an amplifier of this type will be much sharper

(Concluded on next page)

Modernizing Old Sets

Improved Performance is Possible, and Often is Easy to Achieve

PERSONS who own radio receiving sets several years old often ask what to do about the poor results they are now experiencing, especially the interference suffered. They describe the conditions as due to some fault of the set which they are not able to locate.

Of course, the set may be at fault, for the tubes may be worn so as to be insensitive and consequently give "broad" tuning; the several tuning circuits may be out of alignment; dirt or dust may have collected and caused leakage; the neutralizing units may need readjustment.

New Radio Conditions

A great deal of difficulty, however, is encountered by the older radio sets in meeting present-day radio broadcasting conditions. Here are the principal changes in radio that have taken place in the last year or two:

- (1)—More stations.
- (2)—Close 10 kc. separation.
- (3)—Much higher power used.

It is not hard to realize why these conditions are too much for the set manufactured four or five years ago! The increase in power is the most important change that has come about, and it calls for the superior tuning systems of modern radio sets to cope with the situation with full success. How does the modern set do this?

When a simple form of set is made super-selective, as it can be, it will succeed in eliminating interference, but the chances are that the tonal qualities will be poor because the remedy is over-applied. The modulation of a radio wave with voice and music actually broadens the wave slightly. It is necessary to provide as uniform amplification as possible over a band of frequencies about 5 or 6 kilocycles in width, and to shut off abruptly beyond this limit in either direction. A simplified set cannot do that. The new radio outfits utilize four or more separate tuning circuits all ganged together on a single knob control. Each separate circuit is not made especially selective, so that there will not be over-sharpness anywhere to impair the musical qualities. However, the cumulative effect of the succession of several circuits like this results in a sufficient over-all selectivity, with quality preservation, since all circuits are not always precisely in line.

Improving Older Models

What can be done in cases where one does not wish to purchase a new model? Can any improvement be made?

See that the aerial is as short as you can make it, consistent with satisfactory loudness from stations near by. Or, insert a

series condenser (fixed condenser) of about .00025 mfd. capacity between the aerial post and the lead-in.

Be sure you have a very good ground connection. Use a number of different ground connections if possible.

Have all the tubes tested and replace any that are defective or much below normal sensitivity.

Be sure the several tuning circuits are properly aligned. If the set has two or three separate tuning dials, no trouble will be encountered on this score. With single-dial sets, however, the condensers may not be sufficiently well aligned. If you note a tendency for the same station to be heard at one or two places close together on the dial, have the condensers realigned.

Tips on Neutralization

Have the neutralizing units properly adjusted to match the tubes you are using. Perhaps you can do this yourself. Starting with the first radio frequency tube (usually nearest the aerial lead-in) remove the tube. Coat one of the filament (heavy) prongs with collodion (nu-skin or nail polish will do) and replace it. It should not light. Tune in your strongest station, then adjust the neutralizer connected with the first tube until the station is not heard, or at its weakest point. Then remove the tube, scrape off the collodion and replace, so it will light. Next proceed with the succeeding tube in the same way.

Be sure the batteries or eliminators are providing full voltage for lighting the tubes and for the B circuits. Results may be improved by connecting a 2 mfd. fixed condenser from each B plus point to the B minus (or ground).

You can see from the foregoing that radio sets must keep up to date and in step with modern broadcasting conditions. The older models may get by in certain locations and under certain restricted conditions, but in general a more selective set will prove more satisfactory in uninterrupted reception.

May Use Filter Trap

Of course, tremendous improvements have been brought about in tone quality, with power amplifier circuits, big tubes, large dynamic speakers, etc., but with all these important changes in tone qualities do not lose sight of the need for good tuning as well. This will not only enable you to hear natural speaking, and clear, resonant music, but will enable you to hear it from the one station you want, excluding all the others.

A band pass filter wave trap, consisting of two tuned circuits, loosely coupled, may be placed between aerial lead-in and receiver to improve selectivity considerably and without making any change in the receiver. Of course the trap has to be tuned in addition to the set, while the trap also is an external gadget.

Intermediate Frequency Coils

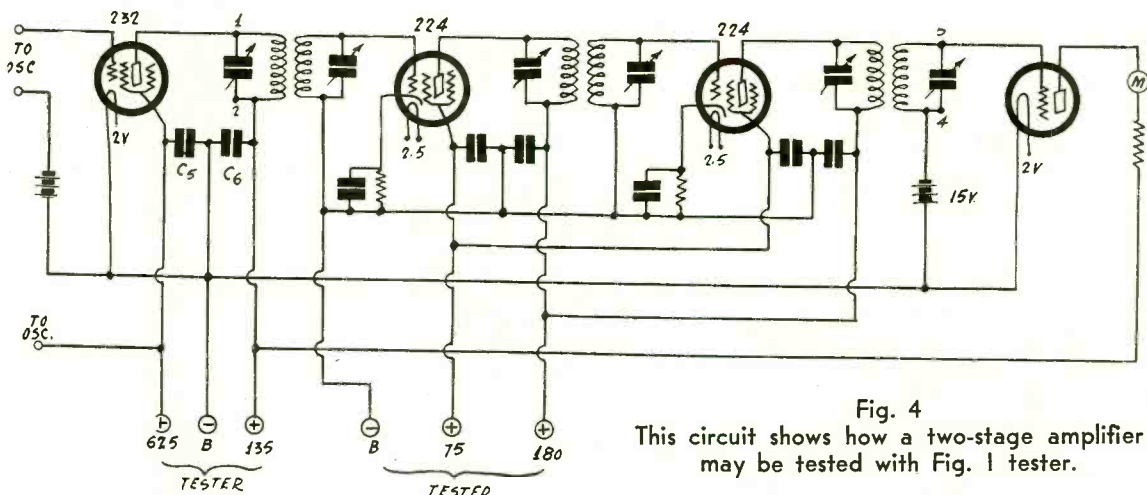

Fig. 4
This circuit shows how a two-stage amplifier may be tested with Fig. 1 tester.

(Continued from preceding page)

than that obtained from a single transformer, provided that all the tuned circuits are adjusted to the same frequency and also provided that all the tubes and transformers are functioning properly. In Fig. 4 is a diagram of a circuit in which an amplifier containing three tuners and two 224 screen grid tubes have been put between the second and the third tubes in Fig. 1. The input leads to the

intermediate frequency amplifier have been marked (1) and (2) and the output leads (3) and (4). The plate and screen voltages for the tested circuit are obtained from a different source from those for the tester circuit, but they may be taken from the same source. B minus of the two parts should be joined when separate voltage sources are used, and in any case B minus should be grounded.

Circuit for Midget Set

By Henry Bohn Hanover

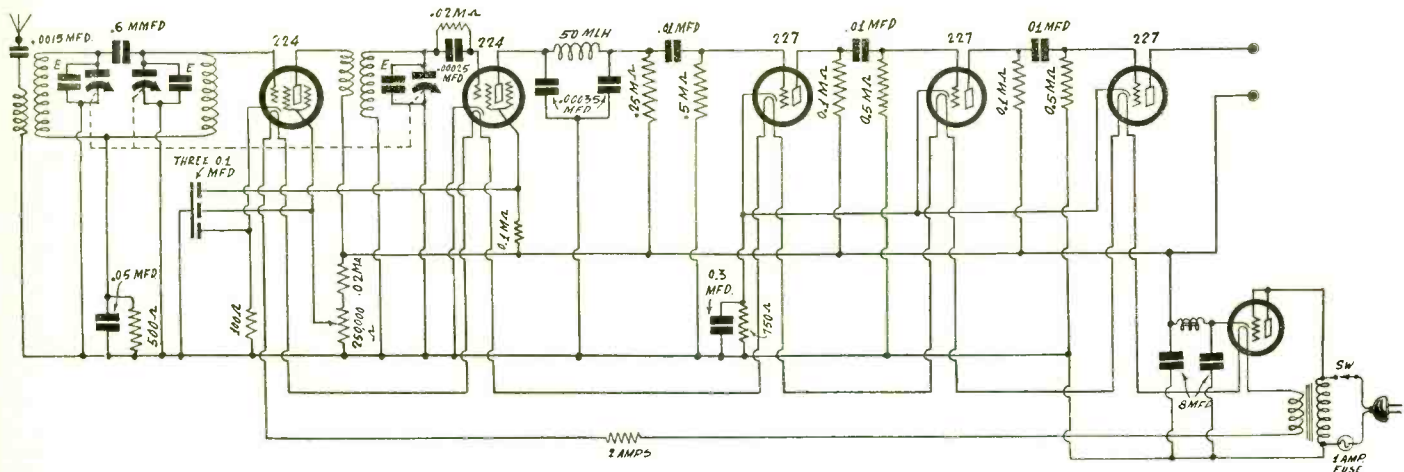

Fig. 1

A very simple but satisfactory circuit for a midget receiver. The plate current drain is only 16 milliamperes. Performance is satisfactory.

THERE is a circuit diagram for a midget receiver, one that draws very little plate current (about 16 milliamperes), and that gives satisfactory performance, despite the few parts used and the simplicity of the design. The circuit consists of a stage of screen grid radio frequency amplification, screen grid detector and three steps of resistance-coupled audio. The rectifier and three audio tubes are 227's.

No External Ground

To make the selectivity satisfactory a band pass filter tuner precedes the first tube. Thus there are three tuned circuits. Each section of the three-gang condenser has a trimmer across it, while the coils are shielded. For .0005 mfd. tuning, using 1 3/4 inch diameter bakelite from 3 to 3 1/2 inches long, the tuned windings should consist of 85 turns of No. 28 enamel wire. The antenna winding consists of 15 turns of No. 28, while the primary in the plate circuit of the screen grid tube has 25 turns of No. 28 or finer wire, if space requirements call for smaller wire, but the primaries may be wound in a slot. The separation between primaries and secondaries is one-eighth of an inch.

No ground is to be attached to this circuit, as ground already

is established through the primary winding of the filament transformer.

Extreme compactness is possible with this circuit, because there is no large power transformer or choke to take up plenty of room, nor audio transformers which, if of good calibre, are likely to be bulky also. The most space taken up by a single part is that occupied by the three-gang condenser.

Condenser Mounting

If the condenser is mounted on a chassis so that the shaft is at right angles to the front panel, requiring a flat dial, then compactness is further served. The other type of dial, a drum, would require for symmetry that the parts be distributed on the side opposite the condenser the same distance as occupied by the condenser. But if a drum dial is to be used, and symmetry not adhered to religiously, then the dial should be off center. It is suggested that a flat type dial be used.

A circuit such as this will come in handy when one wants to build a portable AC receiver, one that can be will take up little room in an automobile, and yet is light enough to carry to a hotel or other place where one will stay when on trips. Then radio reception in one's room becomes almost imperative, and it is handy indeed to have a simple receiver such as this. Also, the circuit is suitable for home use.

Uses for Circuit

A word about the rectifier. It is the simple one discussed several times recently in these columns, and dispenses with special windings. Only a filament transformer is necessary. This one happens to be intended for series connection of heaters, but if you have a 2 1/2 volt filament transformer, you may use that, and connect heaters instead in parallel.

To one side of the AC line, on the set side of the switch, are connected the joined grid-plate electrodes of the rectifier tube. This is done of course at the socket springs, when wiring the receiver. The other side of the primary serves as the B minus lead, and all grid returns are made to this point.

The cathode of the rectifier is positive, as always. Between the cathode and the B plus lead of the set is located a small audio choke coil, or B supply choke. Almost any value of inductance may be included. The primary of an old audio transformer will serve the purpose, the only necessary test being that the primary thus used as a choke should not cause the old transformer to get too hot. Most transformers will not heat up much under the circumstances. The secondary of an old audio transformer should not be used, as its direct current resistance will be too high.

Choice of Filter Capacities

The filter capacities, while 8 mfd. each, do not take up much room, since they are electrolytic condensers. It is not imperative to use such high capacity, but on the assumption the B supply choke will be small, the large capacity is preferable, so that hum will be virtually absent.

If you have condensers of other capacities you may use them, and if the capacities differ, use the smaller one from cathode to B minus, and the larger one from the other end of the B supply choke to B minus. As small a capacity as 1 mfd. may be put next to the rectifier an, but then at least 4 mfd. should go in the other position. The voltage rating of the condensers need not be a subject of concern, as all 1 mfd. or higher capacities are made for a minimum DC working voltage of 200 volts, and the DC voltage here is about 110 volts, if the AC input is 110 volts.

LIST OF PARTS

Coils

- One antenna coupler, one impedance coil, and one screen grid coupler.
- One 50 millihenry shielded radio frequency choke coil.
- One series heater type filament transformer.

Condensers

- One three-gang .0005 mfd. tuning condenser.
- Three Hammarlund 100 mfd. equalizers (E).
- One .00025 mfd. fixed condenser with grid clips.
- One 0.5 mfd. fixed condenser.
- Two blocks, three 0.1 mfd. in each block.
- One 0.6 mfd. Hammarlund band pass filter coupling condenser.
- Three .01 mfd. fixed condensers.
- Two 8 mfd. electrolytic condensers with mountings.
- One .0015 mfd. fixed condenser.

Resistors

- One 500 ohm Electrad flexible biasing resistor.
- One 100 ohm Electrad flexible biasing resistor.
- One Electrad 750 ohm flexible biasing resistor.
- Two .02 meg. (20,000 ohm) Lynch pigtail resistors.
- One 0.25 meg. (250,000 ohm) Lynch pigtail resistor.
- Three 0.1 meg. (100,000 ohm) Lynch pigtail resistors.
- Three 0.5 meg. Lynch pigtail resistors.
- One 250,000 ohm potentiometer.

Other Parts

- One 1 ohm 2 ampere resistor.
- One AC switch.
- One 1 ampere fuse with holder.
- One 1 ampere fuse with holder.
- One antenna binding post and one twin output post assembly.
- Six UY (five-prong) sockets.
- One chassis.
- One dial.
- One front panel.

A Question and Answer Department conducted by Radio World's Technical Staff. Only Questions sent in by University Club Members are answered. Those not answered in these columns are answered by mail.

Radio University

Annual subscriptions are accepted at \$6 for 52 numbers, with the privilege of obtaining answers to radio questions for the period of the subscription, but not if any other premium is obtained with the subscription.

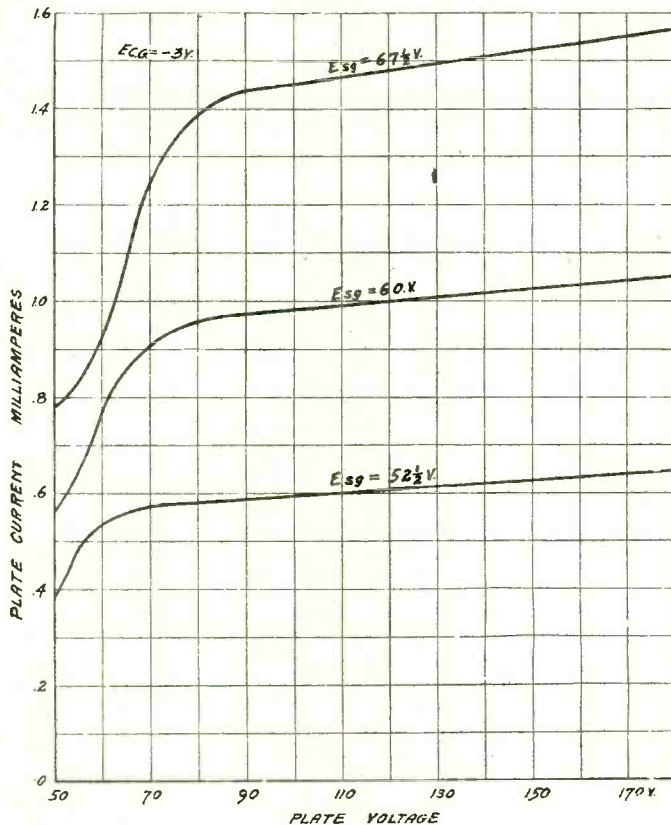

FIG. 900

A family of plate current, plate voltage curves for the 232 screen grid tube showing also the variation in the current as the screen voltage is changed. These curves are typical of all screen grid tubes.

Vacuum Tube for Current Measurements

IS there any way in which a vacuum tube can be used for measuring small current as well as for measuring voltage? If so, will you kindly outline a method?—B.W.C.

There is no very accurate method of measuring current with a vacuum tube. However, there are several ways in which it can be done. For example, if the current to be measured is sent through a fixed resistance of known value, a vacuum tube voltmeter may be used for measuring the drop in this resistance, and as soon as the drop is known the current can be obtained by Ohm's law. If the resistance is 10 ohms, for example, and the current is such that the drop in the resistance is 0.1 volt, which can easily be measured, the current is 10 milliamperes. But a current of this value can best be measured with an ordinary milliammeter, and a smaller current would hardly be measurable by the method. The resistance could be made larger but then the current would be altered by this resistance and thus more or less invalidate the measurement.

Another method of measuring current by a vacuum tube is to send it through the filament in addition to the regular current. The regular current could then be reduced until the total current was the same as it was before the unknown current was superposed. The difference in the filament current reading would then be equal to the unknown. This is applicable when the unknown current is alternating.

Variation of Resistance

IN what manner does the resistance of a wire vary with the temperature? Does the resistance increase or decrease with the temperature? How does it vary with the current through it?—G.B.V.

The resistance of nearly all pure metal wire increases directly as the temperature, and for every degree centigrade change in the temperature the resistance changes very nearly $1/273$ of its value at zero degrees centigrade. Alloys do not behave the same way as pure metals and some hardly change at all. For

example, Manganin has a very small change in resistance with temperature and for that reason it is used in standards.

Use of Variable Mu Tube

WILL the variable mu tube when substituted for a 224 increase the selectivity of a receiver? Will it increase the sensitivity of the receiver?—C.D.W.

It will not increase the selectivity because it does not contain a tuner. It will not increase the sensitivity, either, for at low bias it has about the same characteristics as the 224 and at high bias it does not amplify nearly as well. It will reduce modulation hum and cross modulation, which are due to the same thing, because it was designed to do this.

Improving Voltmeters

CAN any current meter be converted to a voltmeter? If so, is there any general rule respecting the value of the series resistances that should be used?—W.C.M.

Any current meter can be converted to a voltmeter, but the larger the current range of the meter the poorer will the voltmeter be. For example, a voltmeter can be made by connecting suitable resistances in series with a 0-1 ampere meter, but this would make a very poor voltmeter because it would only have one ohm per volt. It could only be used for measuring the voltage of a storage battery or other source of equally good regulation. The rule respecting resistances is that the ohms per volt on the scale should be equal to the reciprocal of the maximum current reading. Thus if the current meter is a 0-1 milliampere, the resistance should be 1,000 ohms for every volt on the scale. Likewise, if the meter is a 0-50 milliampere meter the resistance for every volt should be $1/05$, or 20 ohms. To get the total resistance in any case multiply the maximum voltage reading desired by the ohms per volt. This may be stated in another way. Divide the maximum voltage desired by the maximum current reading to obtain the total resistance. To illustrate, suppose we have a 0-1 milliammeter and we wish to convert it to a 0-500 voltmeter. The two maximum readings in this case are .001 ampere and 500 volts. The total resistance is $500/.001$, or 500,000 ohms.

Free Grid Voltage of Tubes

IS IT a fact that if the grid leak resistance is increased the grid bias is increased in direct proportion? That is, does the grid current remain independent of the grid leak resistance?—J.R.R.

It is not a fact. If it were the grid voltage would be infinite when the grid leak is removed and the grid is left free. The voltage never exceeds the free grid voltage as the resistance is increased and the free grid voltage is usually less than a volt. In some cases it exceeds one volt by a small amount.

Screen Grid Tubes in Audio Circuits

SHOULD the resistance in series with the screen lead be by-passed when the screen grid tube is used for audio amplification in resistance coupled circuits? I refer to the resistance used for the purpose of cutting down the effective screen voltage to prevent it from exceeding the effective plate voltage.—W.K.C.

It should not be by-passed because if it were the condenser would partly nullify the effect of the resistance. If you reduce the applied screen voltage to about one third its usual value you do not have to use the resistance in series with the screen lead.

Curves For 232 Screen Grid Tube

WILL you kindly publish curves showing the relation between the plate current and the plate voltage for the 232 screen grid tubes at different screen voltages? I am particularly interested in knowing whether the plate current increases or decreases as the screen voltage increases and in what manner the variation takes place.—T.C.R.

In Fig. 900 is a family of plate current, plate voltage curves for the 232 tube taken with a control grid bias of 3 volts and three different screen voltages as indicated. The plate voltages given along the horizontal axis are effective voltage and not applied. The effective plate voltage on the tube should be higher than that voltage at which the curves take a sudden rise, which is about 80 volts on the curves illustrated. Since the effective voltage drops as the plate current increases and the plate current depends on the grid voltage, the effective plate voltage will vary with the signal. The 80 volt limit referred

to above is the lowest that the effective voltage should be, and for that reason the operating voltage should be considerably higher to allow for a wide swing. It will be noted that the lower the screen voltage the lower the effective plate voltage may be. Hence when there is a high resistance in the plate circuit it is necessary to decrease the screen voltage to insure good operating conditions and freedom from distortion of the wave form.

Three-Screen Grid Tuner

WILL you kindly publish a radio frequency tuner and amplifier incorporating three screen grid tubes and similar to the circuit used in the Everyman Four?—W. A. C.
You will find the circuit you request in Fig. 901 herewith.

Increasing Converter Sensitivity

WILL a short-wave converter become more sensitive if the oscillator coil is made of the low loss type? Will it be more sensitive if the radio frequency tuner contain such a coil?—S.C.

It makes little difference whether or not the oscillator coil is of the low loss type provided the tube oscillates. Of course, a low loss coil will make the tube oscillate more readily than a poorer coil, and for a given plate voltage the low loss oscillator might oscillate more violently. But this is hardly an advantage because only a certain amount of oscillation voltage can be used on the first detector, and this amount can be obtained from any oscillator. But a low loss coil in the radio frequency tuner is a decided advantage for the lower the losses in the coil the stronger the signals. It is assumed that the two coils are so well shielded from each other, or so loosely coupled, that the RF tuner does not control the oscillation in any way or stop it entirely.

Filter Cut-Off Frequency

I HAVE two choke coils rated at 65 millihenries. With these and two condensers I wish to construct a filter which has a cut-off frequency of 450 kc. If I connect on choke in each side of the line and the condensers across it, one on each side of the coils, what should the capacity of each condenser be?—W.H.J.

The capacity of each condenser should be 1.92 mmfd. This is rather difficult to get since it is smaller than the distributed capacities involved. If you want the cut-off at 450 kc. you had better use smaller choke coils. The cut-off is determined by using the inductance of one of the equal coils and the capacity of one of the equal condensers.

Connection of Phonograph Pick-up

IF A phonograph pick-up unit is connected across the grid bias resistor in a power detector that is self-biased is it necessary to remove the by-pass condenser across the resistance and also is it necessary to change the bias resistor? If the bias resistor used for detection is left across the pick-up is the signal reduced considerably?—C.W.J.

It is necessary to remove the by-pass condenser because this is so large that all but the lowest audio notes would be attenuated to almost nothing. It is not necessary, however, to change the bias resistance because the shunting of the unit automatically changes the resistance. The high resistance across the unit, which for detection is 15,000 ohms or more, will attenuate the phonograph signals appreciably and if there is not much amplification at audio frequencies it is best to disconnect the resistance and leave the pick-up in the cathode lead alone.

Perhaps a better way of connecting the pick-up is in series with the tuning coil. A short circuiting switch should be provided so that when radio signals are to be received the pick-up may be cut out. The unit should be on the low side of the coil. When this method is used the bias resistor should be reduced when the phonograph is in the circuit.

Self-Bias in Resistance Coupling

SHOULD the bias resistor be of the same value in a resistance coupled circuit as in a transformer circuit when the same tube is used? If not, how is the resistance determined?—E.S.

It should be larger because the current through it is smaller. The grid bias should be the same, though. To determine the proper bias resistance it is necessary to measure or estimate the plate current in the tube when the proper bias is applied with a battery and the resistance should be obtained by dividing the required bias by the current. Suppose, for example, that the required bias is 13.5 volts and the current is found to be 0.75 milliamperes, the resistance should be 18,000 ohms. If the desired bias is less, or if the current is greater, the resistance will be less.

By-Passing Bias Resistor

DO YOU recommend the use of a by-pass condenser across the bias resistor in a push-pull stage? I have noticed that in some cases a condenser is used, but in the majority of cases there is no condenser at all. Should a condenser be used across the bias resistance in a single sided amplifier? If it is omitted what is the effect on the amplification?—L.W.
It is neither necessary nor desirable to use a by-pass condenser

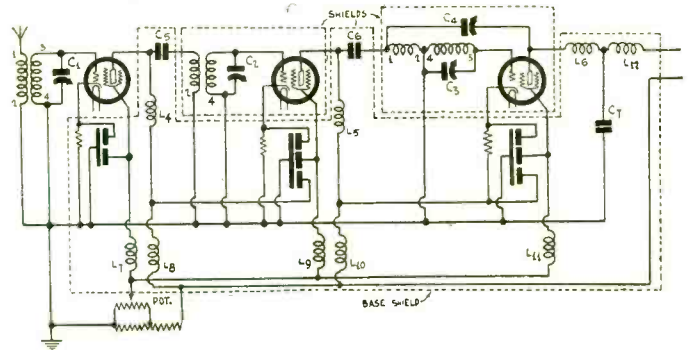

FIG. 901

A sensitive three-tube screen grid amplifier similar to the circuit in the Everyman Four receiver. Thorough filtering of the supply leads is used to prevent instability.

across the bias resistor in a push-pull stage because if the circuit is balanced there is nothing to by-pass and if the circuit is not balanced the resistor will help to effect a balance. A condenser would nullify this effect. In a single sided amplifier the bias resistor should always be by-passed because otherwise the amplification would be reduced considerably. And the condenser should be large for otherwise the reduction will only occur on the low audio frequencies.

Determining Ballast Resistors

CAN you give us a method for determining the required ballast resistors for the different kinds of tubes?—W.A.C.
There is always a simple way of going about it. Subtract the filament voltage required from the voltage of the A battery or other filament voltage source. Then divide the difference by the current required by the tube. The result is the required ballast. It holds for all tubes. Take the 231, for example, which requires a filament current of 0.13 ampere and a filament terminal voltage of 2 volts. Suppose the voltage of the filament battery is 3 volts. The difference between the battery voltage and the filament terminal voltage is one volt. Hence the ballast resistance should be 1/13 ohms, or 7.7 ohms.

Increasing Selectivity

IF I tune both the primary and the secondary of a radio frequency tuner will I get a greater selectivity, and if so, will it be enough greater to justify the trouble?—C.L.D.
Tuning both windings will make the selectivity greater or less depending on the degree of coupling. If the coupling is close the selectivity will not be at all good, but if the coupling is loose it will be high. If you make the coupling loose and tune the circuits accurately to the same frequency the selectivity will be high enough to justify the extra condenser.

Making Converter Sensitive

IN THE Feb. 7th issue you published a converter containing three tubes, a modulator, an oscillator, a radio frequency amplifier. Would this receiver be more sensitive if I tuned the input choke Ch1, that is, if I substituted a radio frequency coil for this and tuned it?—B.R.L.
It would. But to get much benefit you have to make the coupling between the antenna and the tuned circuit very loose.

Receiving Beam Short-Wave Signals

I HAVE tried to receive commercial short-wave, point-to-point signals but I have not had any luck. Yet my short-wave receiver is very sensitive, for I can get signals from all over the world. What do you think is the reason I have not been able to pick up the conversations?—L.C.K.
The reason is probably that the signals you have been trying to get are on a beam and that you are not within the beam. Point-to-Point communication by means of short waves, especially over long distances, is usually carried out on the beam method because it affords greater privacy and reliability, and also because it takes less power than when signals are sent broadcast.

Taking Resonance Curves

WILL you kindly explain a method of taking resonance curves on tuned circuits such as intermediate and radio frequency couplers? I should like to have a method employing devices such as are readily available to the radio experimenter.—W.H.K.
An article describing a method for taking such curves is printed in this issue. All the parts, with the possible exception of the milliammeter, are available in every experimenter's laboratory. If a 0-1 milliammeter is not available a 1,000 ohms per volt voltmeter can be substituted for in effect the meter used is nothing but that. If a less sensitive voltmeter or milliammeter is available that too can be used.

A Thought For the Week

NELLIE REVELL, noted newspaper-woman, Broadwayite, member of a famous family of stage folk, writer of books (remember her "Right off the Chest," conceived and partly written while she was an invalid in a New York hospital?) is on the air on Wednesday nights from 11 to 11:15. Miss Revell calls radio "the fifth estate." She knows the newspaper and amusement field inside out and crossways and has a personality that is winning her millions of new friends, who like the something or other that distinguishes one human from the others. Nellie Revell has a tang of her own!

RADIO WORLD

The First and Only National Radio Weekly
Ninth Year

Owned and published by Hennessy Radio Publications Corporation, 145 West 45th Street, New York, N. Y.
Roland Burke Hennessy, president and treasurer, 145 West 45th Street, New York, N. Y.; M. B. Hennessy, vice-president, 145 West 45th Street, New York, N. Y.; Herman Bernard, secretary, 145 West 45th Street, New York, N. Y.
Roland Burke Hennessy, editor; Herman Bernard, business manager and managing editor; J. E. Anderson, technical editor.

The Spirit of Compromise

EVERY good radio set is a remarkable demonstration of the importance of compromise or proper balance between the means and extremes in radio principles.

The aerial system is itself an outstanding compromise. If the aerial is made very long it intercepts a large amount of energy and as a result stations come in with great volume. But when this is done the selectivity is poor and interference great. On the other hand, if the aerial is too short, the interference is avoided, but the volume is not great enough.

How selective shall we make our radio sets? Originally, before much thought was given to tonal characteristics, it was felt important to obtain "hair-breadth" selectivity so as to avoid all possible interference. Then it was realized that excess sharpness spoiled the naturalness of voice and music, because a broadcast wave is really a complexity of frequencies which require a band of waves at least 5 kilocycles on either side of the carrier. If the set tuned sharply only to the exact carrier frequency, the lower tones would be heard in a sort of drum-like effect.

This compromise is one of the most important in radio. The best solution so far discovered is of a sharp input selector and designing each succeeding stage to tune relatively broadly and then by combining a succession of three to five such circuits to achieve great amplification and an over-all high degree of selectivity without sideband cutting.

The principle of careful balance between extremes is well illustrated in the loudspeaker. Originally the radio speaker was a tinny sounding affair which had a small vibrating diaphragm and a horn to give direction to the sound and enable it to "get a grip" on the air. This emphasized the higher-pitched tones unduly, and during recent years a tremendous improvement has been made in this respect. For a time loudspeakers were designed to bring out the lower tones, and then the higher tones suffered.

It is very difficult and nearly impossible to design a loudspeaker that has an abso-

lute flat or uniform reproduction as to loudness on all voice and music tones from 30 cycles to 5,000 cycles.

Some years ago a radio listener operating the regulation 5-tube set said he required three hands to get along well, because there were three separate tuning dials, to say nothing of other controls for volume, etc. Then came ganging of these separate controls so that only one tuning knob had to be adjusted. This presented a very hard problem and, in fact, it still must receive major attention as the multiplicity of the circuits goes on. If the tuning condensers were too critical in adjustment, it was very difficult to make them all work together properly. If the circuits were altered so that the condensers need not be adjusted so accurately, selectivity suffered. Various small compensating units were devised so that inequalities could be taken care of and a proper compromise between the difficult limits was eventually reached.

It was found that if a small fixed condenser or a combination of a condenser and a choke coil was connected across the loudspeaker or some of its associated amplifying units, the tone average was lowered so the bass notes were more pronounced in comparison to the high tones. Some sets utilize such devices to offset lack of low-note amplification, although the better class set does not need this treatment.

Where the tone control unit has too large capacity the effect is to reduce the volume considerably and to produce a muffled or deadened tone because of the elimination of the high notes. Here again a proper selection is needed.

In many sets, especially those of lower cost, the tone control improves the reproduction considerably, but the device should either be adjustable or selected to match the set in question.

In regenerative sets or in radio frequency amplifiers there is a compromise point for volume beyond which the set either oscillates or gives poor tone qualities. Accordingly amplification cannot be pushed beyond certain limits without impairing the reception, even though the volume might be greater.

Large coils generally provide better tuning characteristics—provided they are not close to other objects. This shows an important compromise in modern radio building, for with the necessity for shielding and compactness, the large coil would become very inefficient if too closely bottled up. Hence you may see in up-to-date sets coils of minute proportions, one inch or so in diameter, wound with very fine wire, in small shields. Of course, this can be overdone, and result in coils of too high resistance, so that volume would be reduced and selectivity would be poor.

What Circuit Is Best?

WHAT radio receiving set is the best? What radio circuit is the best?

In general, no one can conscientiously recommend that any special circuit or make as the best. To the uninitiated, about to purchase a new set to receive broadcast programs, the best advice is to use a well-known circuit. Among the numerous popular circuits one always gets good value. The more expensive models generally incorporate additional features and higher grade apparatus so that the resulting tone will be nearer to the ideal.

To the radio beginner who wants to know more about radio than the mere turning of knobs, a general education, obtainable through magazines, radio clubs, books, etc., on radio receiving circuits and principles will serve to clear the mind on the comparison questions. He will find that there are many ways to accomplish the object, that all these ways have some usefulness, and that by a correct combination of certain ones, the object can be gained.

KMOX Will Occupy Fine New Studios

The Voice of St. Louis, Inc., which operates KMOX, has closed contracts with the St. Louis Mart, Inc., which provide for new broadcasting studios occupying space on two floors of the new \$5,000,000 St. Louis Mart Building, under construction at Twelfth boulevard and Spruce street. The new studios will be three times as large as the present ones.

Engineers of the Columbia Broadcasting System, of which KMOX is the most powerful transmitting unit, approved the design of the new studios, which will cost \$250,000, including complete new electrical equipment at \$100,000.

Due to the increased facilities, KMOX is expected to become the originating station for many of the programs broadcast over the entire Columbia chain. Some chain programs are originated by KMOX now, but the proportion is expected to increase.

1,000 Will Be Heard in Record Air Chorus

The largest chorus of trained voices ever heard on the air will face NBC microphones in the Greek amphitheatre at the University of Virginia Thursday afternoon, April 16th, in the broadcast of one session of a four-day program of the Virginia State Choral Festival Association. A thousand voices will sing Schubert's Mass in B Flat, accompanied by the Manhattan Symphony Orchestra under the direction of Dr. Tertius Noble, of New York.

The presentation will last an hour, beginning at 3:30 P.M., Eastern Standard Time, and will be heard over an extensive NBC network.

WDAY and KFJR Join the National Network

WDAY, Fargo, N. D., and KFJR, Bismarck, N. D., joined the NBC network. WDAY operates 940 kc and 1,000 watts power. It was inaugurated on May 22, 1922, and is the oldest station in the Northwest. The station recently moved into new studios and installed new transmitting equipment.

KFJR, operates on 550 kc and a power of 2,500 watts during the day and 1,000 at night. It is owned and operated by the Meyer Broadcasting Company.

"More Orders From Radio World Ad Than We Can Fill"

Philadelphia, Pa., March 7, 1931.

Advertising Manager
Radio World,

Kindly discontinue our ad. Have received more orders from Radio World ad than we can fill for some time to come.

Kindly send credit on difference.
Thanks.

Whenever we have any advertising on radio parts, we surely will use Radio World.

Very truly yours,
PHILADELPHIA ARMATURE
WORKS.

Per A. Apfelbaum.

2711 Girard Avenue,
Philadelphia.

COSMOPOLITAN TONGUE IS GOAL OF ANNOUNCERS

Attacking recent contentions for sectionalized pronunciation of the English language in radio, numerous authorities on pronunciation have urged a continuation of National Broadcasting Company's policy of eliminating, so far as possible, sectional and provincial pronunciations in favor of a nationally recognized standard of English usage and pronunciation that might be termed "cosmopolitan English."

In their broadcasting, NBC announcers endeavor to use pronunciations that are generally approved by cultured persons, that will be widely understood by English-speaking people wherever they are, and that are free from the extremes of affected precision or fashion on the one hand, and from all that savors of archaism, ignorance, or slovenliness on the other.

A Decisive Moment

Paul W. Carhart, pronunciation editor of the G. & C. Merriam Company, Springfield, Mass., publishers of Webster's dictionaries, recently said:

"Never before has the English-speaking world faced such a decisive moment in the matter of pronunciation, and because of the influence of radio, especially, is this more than ever of interest."

Widely different dogmatic opinions have been received by NBC regarding the pronunciations used by various announcers.

"But as far as that is concerned," declared Vida Ravenscroft Sutton, voice and diction coach of NBC announcers, "we seriously endeavor to use 'cosmopolitan English' as a satisfactory compromise."

Must Consult Authorities

"There are thousands of dialects in the United States. Without travel and education people could develop as many tongues as we have towns. It would be next to impossible to standardize speech," she said.

NBC announcers are required to consult three standard dictionaries for difference of opinion and one English pronouncing dictionary for phonetics, as reasonable protection against errors.

THE AIR SHAFT

Two friends of long standing met recently in the NBC studios, when Marcella Shields, diminutive member of The Two Trouters, collided with a gentleman in the elevator, to discover, in the midst of ensuing apologies, that her victim was her former vaudeville partner, Johnny Kane. They had "done an act" together for two years before Marcella went on the air. And now Kane has followed her to broadcasting, and is heard every Saturday night in NBC's college serial, "The Campus."

Ezra McIntosh, 23-year-old NBC announcer, first became interested in radio at twelve years of age when a spark transmitter was given to him. During that youthful year he learned the Morse continental code.

Miss Madge Tucker, director of the Lady Next Door and other NBC features, recently received a bread pudding from a listener.

Only One Radio Bill Enacted

Washington.

Out of 48 measures dealing with radio, only one was enacted into law during the third session of the 71st Congress, Elmer A. Lewis, Superintendent of the House Document Room, said:

This bill authorized the Bureau of Standards, Department of Commerce, to make more intensive studies of static and fading, and to set up a sharp-tuning service, by which broadcasting stations, and technically inclined listeners may calibrate their sets for close frequency adherence. It carried an authorization of \$147,000, for the construction of additional transmitters and other equipment to carry on the work.

PROGRAM PUT ON AUDIO MOVIE

For the first time in history sound motion pictures have been made simultaneously of a radio program's origin and its reception at three widely separated points.

A recent Westinghouse Salute was broadcast from the National Broadcasting Company's Times Square Studio in New York, and was received in the gondola of a dirigible floating over Los Angeles, in a submarine cruising with the United States fleet near the Panama Canal, and thirty stories underground in Mammoth Cave, Kentucky.

Engineers in charge of the experiment reported highly successful results. The sound and sight records were assembled for showing in motion picture theaters throughout the country. Radio engineers studied these records to determine the effects obtained from picking up a program not only in the air above the earth but within the earth and beneath the waters as well. They will also use these film records in experiments to perfect tone qualities in radio and sound motion picture apparatus.

Samples of the recorded films will be presented to the director of naval communications, Navy Department, Washington, for the use of government research engineers.

Dumont Announcer

Paul Dumont, whose radio association dates back to the early days of station WJZ, returned to the announcing staff of the National Broadcasting Company after three years as production man. Dumont first sang over WJZ in 1923. He was then accompanied at the piano by Keith McCleod, now NBC musical supervisor. The program was announced by Milton Cross.

New Corporations

- Ford Radio and Accessory Corp. of America, Dover, Del., radio and radio equipment—Atty. Arley B. Magee, Inc., Dover, Del.
- Empire Broadcast Corp., New York—United States Corporation Co.
- Bloomfield Radio Laboratories, Inc., Bloomfield, N. J., radio supplies, etc.—Atty. Abraham Rudensky, Newark, N. J.
- Howard Radio Sales Stores—Attys. Hyman & Hyman, 103 East 125th St., New York.
- G. H. Amusement Co., Jersey City, N. J., radios—Attys. Gross & Gross, Jersey City, N. J.
- Stanen's Radio Shop—Atty. M. G. Kantrowitz, 305 Broadway, New York, N. Y.
- Atlas Radio Corp.—Atty. B. M. Brody, 261 Broadway, New York, N. Y.
- Frost-Minton Corp., radio business—Attys. Wilcox & Van Allen, Buffalo, N. Y.
- Cortlandt Salvage Corp., radio devices—Attys. Siegmeister & Rayfel, 26 Court St., Brooklyn, N. Y.

JOBS INCREASE IN SET PLANTS

Washington.

Employment is increasing in the radio industry preparatory to a seasonal resumption of activity, according to a statement received by Colonel Arthur Woods, chairman of the President's Emergency Committee for Employment, from Bond Geddes, executive vice-president of the Radio Manufacturers Association, New York City.

"Radio manufacturing is seasonal to a large extent," says Mr. Geddes. "Our peak production usually begins in June and extends at top load well into August or September.

"We believe this seasonal expansion will occur this year to an extent governed by special conditions relating to the demand for products. In anticipation, receiving set manufacturers already have begun to place orders, thus stimulating production among parts, speaker, and accessory manufacturers. The increase in labor already has been considerable with more to come as the season advances.

"This association represents over 200 companies making up about 95 per cent of the output of the entire radio industry. Employment during last summer's peak for the entire industry was about 35,000 persons, including both wage earners and salaried personnel. We are urging all our member companies to consider every means to spread the work among as many persons as may be economically practicable. Wage rates are being maintained."

This is one of a large number of reports received by the President's Emergency Committee which is circulating its suggestions for industrial employment, through the co-operation of trade associations. More than 100 such groups are helping in this work. Specific measures which can be and are being applied by individual companies are summarized in two pamphlets entitled "An Outline of Industrial Policies and Practices in Time of Reduced Operation and Employment" and "A Survey of Unemployment Relief in Industry." Copies are available on request from the Committee's offices in the Department of Commerce Building, Washington, D. C.

Literature Wanted

Readers desiring radio literature from manufacturers and jobbers concerning standard parts and accessories, new products and new circuits, should send a request for publication of their name and address. Send request to Literature Editor, RADIO WORLD, 145 West 45th Street, New York, N. Y.

- C. A. Norwood, Quesnel, B. C., Canada.
- A. McDowell, 502 Simcoe St., Winnipeg, Man., Canada.
- City Garage, Mullan, Idaho.
- H. C. Dullimore, 138 W. Prospect Ave., Jackson, Mich.
- J. G. Jones, D. V. M., Oregon, Ill.
- Dr. F. A. Spencer, Portsmouth, Ohio.
- Walter Abramowski, 2709 W. 23rd Pl., Chicago, Ill.
- Leon Kruger, 8259 Melrose Ave., Los Angeles, Calif.
- William Hutton, 234 11A St., N. W., Calgary, Alta., Canada.
- Oatha Colwell, 1134 5th Ave., N. W., Calgary, Alta., Canada.
- C. B. Brontley, Sturkis, Ky.
- E. E. Kelley, 443 High St., Cor. Essex, Holyoke, Mass.
- Samuel Spiro, 171 Highland Ave., Washington, Pa.
- Charles H. Van Tassell, 421 DeWitt Street, N. Linden, N. J.
- H. F. Westien, Electrical Work & Supplies, Menasha, Minn.
- United Radio & Electrical Co., 959 W. Big Bend, Kirkwood, Mo.
- William Reardon, Box 4341, Miami, Fla.
- Jack Shafer, Box 718, Little River, Fla.
- Donald E. Prim, Box 18, Rutledge, Pa.
- F. J. Bussone, 870 Milton Ave., Chicago, Ill.
- Don. K. Follett, Richville, Minn.

How Would You Like To Know

- 1.—Where you can save money by purchasing at bargain prices mail order radio merchandise.
- 2.—How you can keep posted on "What's New in Radio."
- 3.—How to receive mail from leading radio mail order houses, manufacturers, jobbers, etc.

This Handy Practical Portfolio
FREE!



Every subscriber to our service receives a 10 by 12-inch accordion portfolio made of a durable material, in which to save the valuable data we send you.

NATIONAL RADIO TRADE DIRECTORY,
303 Fourth Avenue, New York. Dept. W.

Gentlemen:
Enclosed please find \$1.00 for one year's subscription to your "Big Mail" and "Radio" Information Service. It is understood that you are to put my name on your stencil list to receive mailings, including catalogs, bulletins, price lists, samples, etc. I am also to receive free a 10 to 12-inch accordion portfolio.

NAME

ADDRESS

CITY STATE

- 4.—How to have your radio problems answered; where to locate the manufacturer of a certain product; the name of a jobber handling an item you wish to secure; the manufacturer of a trade-marked product.

Your name is placed on our stencil list to receive for a years time a constant supply of advertising matter, catalogs, circulars, price lists, samples galore.

You are privileged to write us at any time, questions pertaining to radio trade matters and receive a prompt and detailed reply.

No live radio dealer, fan, amateur, experimenter or professional can afford to be without our comprehensive service.

Our business is the nerve center of the radio industry, reaching out everywhere, collecting data from every available source, maintaining the most complete service of its kind in the world.

all for \$1

You will realize that the amount we spend for postage alone does not cover the charge for our service. The subscription fee barely pays the necessary expenses entailed in mailing.

A subscription to our service will actually save you many times the small cost of \$1.00.

If there is any additional information you may require before subscribing, write for further details.

PARTS FOR BERNARD'S DIAMOND MIDGETS

3-tube AC tuner, less B supply, complete parts as specified by Herman Bernard. Pre-selector tuning, space-wound shielded coils, aluminum chassis drilled for socket holes. High sensitivity. No cross-modulation. Adequate selectivity. All parts (less tubes, less front panel) order Cat. DHST \$17.28 @

AC tuner, with B supply built in, using 227 as rectifier; two 224 RF tubes, 227 detector. Same circuit as DHST, except that special rectifier circuit is added, so that tuner may be worked with audio power amplifier that provides no external voltage. All parts (less tubes, less front panel) order Cat. DHBT \$21.82

Complete AC receiver, with the same tuner as the others, but with three-stage audio, with 245 output. All parts fit on a 12" wide x 9 1/4" front-to-back chassis, with elevating flap 3" high. Filtration perfect (24 mfd. used). Requires two 224, three 227, one 245, one 280. All parts (less tubes, less front panel) order Cat. DACR \$31.09

Battery-operated tuner, using two 232 RF and one 231 tube (new 2-volt type), affording same sensitivity and selectivity as either model AC tuner. Just the thing for those whose homes have no electricity. Supplied with cable connector plug for extreme convenience in connecting batteries. All parts (less tubes, less front panel) order Cat. DBTU \$16.94 @

The complete battery-operated receiver, six tubes (two 352, three 230, one 231). All parts (less tubes, less front panel) order Cat. DBB \$23.91
Note: All models use same front panel. Supplied in bakelite, 7 x 12 inches, drilled for BEL dial, volume control and switch, to coincide with chassis. Order Cat. DFP-Black, or DFP-Walnut @... \$1.62

GUARANTY RADIO GOODS COMPANY, 143 WEST 45th STREET, NEW YORK, N. Y. (Just East of Broadway)

Quick Action Classified Ads

Radio World's Speedy Medium for Enterprise and Sales

7 cents a word—\$1.00 minimum—Cash with Order

A-B-C- POWER PACKS 110 volt, 60 cycle, for sets using 1 1/2, 2 1/2 and 5 volt tubes or for electrifying battery sets. Packs are well made, filtered with Potter Condensers and are remarkably free from hum. Complete with 280 tube, \$6.25. Cash Radio, 1013 N. McDonel St., Lima, Ohio.

NEW PHILCO 96, 1931, A.C. 9 Tubes, Highboy. Cost \$189.00. Sell \$85.00. E. A. Fountain, 436 E. 138th Street, Apt. 5L, New York.

"A B C OF TELEVISION" by Yates—A comprehensive book on the subject that is attracting attention of radioists and scientists all over the world. \$3.00, postpaid. Radio World, 145 West 45th St., N. Y. City.

SHORT-WAVE NUMBERS OF RADIO WORLD. Copies of Radio World from Nov. 8, 1930 to Jan. 3, 1931, covering the various short-wave angles, sent on receipt of \$1.00. Radio World, 145 W. 45th St., N. Y. City.

MILLION PARTS. Replacements for Freshman, Earl, etc. Radio hardware, small and big stuff. Price list just out for out-of-town experimenters, repair men. Experimenters Radio Shops, 129 West St., N. Y. C.

SCOTT WORLD RECORD SUPERHET, Demonstrator, with radiotrons, \$29.50. Jaeger, 607 West 138th St., New York City.

"FORD MODEL 'A' CAR." Its Construction, Operation and Repair, By Victor W. Page, M.E. 545 Pages, 251 Specially Made Engravings. \$2. postpaid. Radio World, 145 W. 45th St., N. Y. City.

SOUND PICTURES TROUBLE SHOOTER'S MANUAL, by Cameron and Rider, an authority on this new science and art. Price \$7.50. Book Dept., Radio World, 145 W. 45th St., N. Y. City.

"HANDBOOK OF REFRIGERATING ENGINEERING, by Woolrich.—Of great use to everybody dealing in refrigerators. \$4. Book Dept., Radio World, 145 W. 45th St., N. Y. City.

SALESMEN WANTED. 87 MILES ON 1 GALLON OF GAS?—Startling Vapor Gas Saver. All Autos, Motorcycles. 1 Free. Critchlow, 3360-A. Wheaton, Ill.

"MATHEMATICS OF RADIO"—A great help to everybody interested in radio. \$2 postpaid. Radio World, 145 W. 45th St., N. Y. City.

HORN UNIT, \$1.95—This is the Fidelity Unit and has stood the test of time. Guaranty Radio Goods Co., 143 W. 45th St., New York.

RADIO WORLD AND RADIO NEWS. Both for one year, \$7.00. Radio World, 145 W. 45th St., N. Y. City

BARGAINS in first-class, highest grade merchandise. Phono-link pick-up with vol. control and adapter, \$3.32; four-gang .00035 mfd. with trimmers built in, \$1.95; .00025 mfd. Dubilier grid condenser with clips, 18c. P. Cohen, Room 1214, at 143 West 45th Street, N. Y. City.

Radio Dealers **YOUR** **Service Men**
Business Will Improve
If You'll Keep Your Name Before Your Customers Everyday
HOW? See Illustrations Below

Most people don't remember the day, the station, the dial number and hour of their favorite radio programs and they will gladly welcome and appreciate a Radiominder Card with ample spaces to record all this information. A card like this will be kept for the longest time in any home.

Give RADIOMINDER Cards

with your Ad on to every one of your customers or place one in every home in your neighborhood and they will not only quickly remind of the daily radio programs but will also keep your name before your customers and thus keep them thinking of you

There is no better way to make people think of you everyday.

These cards are far superior to business cards and their cost insignificant when you consider the benefits you will derive. To enable you to test their value we will accept your order for as little as



100 Radiominders with your "Ad" of 5 lines **\$1.00** Postpaid

Each additional 100 Cards only 50c (For points west of Mississippi, add 10c for postage.)

The regular size of these cards is 3 1/2 x 5 1/2 inches, the space for your Ad is 1 x 3 inches and they are printed very attractively on heavy golden rod bristol card.

Use pen and ink, write plainly or type your copy for 5 lines on any paper and mail to-day with remittance to—

THE ROTH PRESS

846 Sutter Ave. Brooklyn, N. Y.

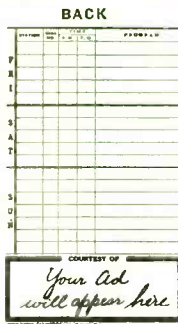

COURTESY OF
Your Ad will appear here

FREE RADIO CATALOG
COAST TO COAST RADIO CORPORATION
 HEADQUARTERS ALL RADIO REPLACEMENT PARTS
 142 W. LIBERTY ST., NEW YORK

BIG 3 FT. TELESCOPE
 Five Sections, Brassbound, Powerful Lenses, 10-Mile range. Special Eye-Piece for looking at the sun, included FREE. Can be used as a Microscope. Guaranteed. Big value. Postpaid \$1.75. C.O.D. 15c extra.
BENNER & CO., T-67, TRENTON, N. J.

The inductor dynamic offers high sensitivity and true tonal response. It requires no exciting field current, unlike other dynamics. Order model B for 112 or 112A, and Model G for all other output tubes.

- Cat. 9-G (9" extreme outside diameter) \$8.49
- Cat. 9-B\$8.49
- Cat. 12-G (12" extreme outside diameter)\$10.03
- Cat. 12-B\$10.03

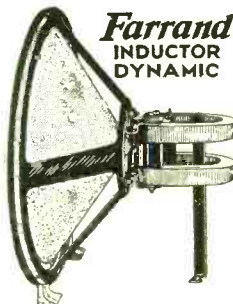

GUARANTY RADIO GOODS CO.
 143 W. 45th St., New York, N. Y.

NEW...
SMALLER—LIGHTER
A CARDWELL QUALITY CONDENSER AT A LOWER PRICE!

For receiving, up to 365 MMF.
 For transmitting, up to 150 MMF.



THE CARDWELL MIDWAY FEATHERWEIGHT SEE IT!
 SOLD IN NEW YORK CITY BY
LEEDS RADIO 45 VESEY STREET
SUN RADIO 64 VESEY STREET
WM. EGERT 179 GREENWICH ST.
 LITERATURE ON THESE AND OTHER CONDENSERS ON REQUEST.
THE ALLEN D. CARDWELL MFG. CORP.
 95 Prospect Street, Brooklyn, N. Y.

DEALERS AND SERVICEMEN SEND FOR IT
Federated Purchaser
 18E Hudson Street New York City

DEALERS and SERVICE MEN! STANDARDIZE ON
LYNCH METALLIZED RESISTORS
 For Permanent Replacement—Accurate—Guaranteed
 Write for descriptive catalogue "W"
LYNCH MFG. CO., INC., 1775 Broadway, New York

- REPLACEMENT CONDENSER BLOCKS**
 A. K. 37 (Chokes & Condensers).....\$3.75
 Majestic Master "B".....\$2.25
- REPLACEMENT POWER TRANSFORMERS**
 R. C. A. 17, 18, 33, 51.....\$3.75
 R. C. A. 44, 46.....\$3.90
 Zenith, all models 52 up to 77.....\$6.50
 Write for price list of replacement parts.
BRONX WHOLESALE RADIO CO.
 7 W. Tremont Ave. New York, N. Y.

CICO CELL
 PRACTICAL PHOTO-SENSITIVE CELL OF MERIT
 SMALL—UNBREAKABLE—POSITIVE
 A SWITCH THAT IS OPERATED BY A BEAM OF LIGHT.
 SUITABLE FOR COUNTING, SORTING, TRAFFIC CONTROL, ALARMS & ETC.
 PRICE \$5.50—POSTPAID
CLARK INSTRUMENT CO.
 119 N. 4th ST., CAMDEN, N. J.

Horn Unit \$1.95

 The Fidelity unit is pre-eminent for horn type speakers such as exponential horns. The faintest word from a "whispering tenor" or the tumultuous shout of the crowd or highest crescendo of the band is brought out clearly, distinctly. Stands up to 450 volts without filtering. Works right out of your set's power tube, or tubes requiring no extra voltage source. Standard size nozzle and thread. Works great from AC set, battery set or any other set, push-pull or otherwise. The casing is full nickel finish, highest polish.
 This unit can be used in a portable without any horn attached and will give loud reproduction.
 Order Cat. FDU, with 50-inch tipped cord; weight, 2 1/2 lbs.; size, 2 1/2-inch diameter, 2 1/2-inch height. (This is the large size). Price.....\$1.95

GUARANTY RADIO GOODS CO.
 143 West 45th Street, New York City
VERSATILE SPEAKER UNIT—FOR HOME OR PORTABLE
FIDELITY HORN UNIT. Stands up to 450 volts without filtering. Order Cat. FDU, with 50-inch tipped cord, weight 2 1/2 lbs.; size 2 1/2-inch diameter, 2 1/2-inch height. Price, \$1.95. Guaranty Radio Goods Co., 143 West 45th St., N. Y. C.

Two for the price of One

Get a **FREE** one-year subscription for any **ONE** of these magazines:

- CITIZENS RADIO CALL BOOK AND SCIENTIFIC DIGEST** (quarterly, four issues).
- RADIO LOG AND LORE.** Quarterly. Full station lists, cross indexed, etc.
- RADIO** (monthly, 12 issues; exclusively trade magazine).
- RADIO ENGINEERING** (monthly, 12 issues; technical and trade magazine).
- RADIO INDEX** (monthly, 12 issues) Stations, programs, etc.
- SCIENCE & INVENTION** (monthly, 12 issues; scientific magazine, with some radio technical articles).
- AMERICAN BOY—YOUTH'S COMPANION** (monthly, 12 issues; popular magazine).
- BOYS' LIFE** (monthly, 12 issues; popular magazine).

Select any one of these magazines and get it **FREE** for an entire year by sending in a year's subscription for **RADIO WORLD** at the regular price, \$6.00. Cash in now on this opportunity to get **RADIO WORLD WEEKLY**, 52 weeks, at the standard price for such subscription, plus a full year's subscription for any **ONE** of the other enumerated magazines **FREE!** Put a cross in the square next to the magazine of your choice, in the above list, fill out the coupon below, and mail \$6 check, money order or stamps to **RADIO WORLD**, 145 West 45th Street, New York, N. Y. (Just East of Broadway).

Your Name

Your Street Address

City State

- If renewing an existing or expiring subscription for **RADIO WORLD**, please put a cross in square at beginning of this sentence.
- If renewing an existing or expiring subscription for other magazine, please put a cross in square at the beginning of this sentence.

RADIO WORLD, 145 West 45th Street, New York, N. Y. (Just East of Broadway)

DOUBLE VALUE!

KFI 68.5 KILOCYCLES METERS DIAL Los Angeles, 50,000 WAUF—Columbus, O. . . . 500	IT 405.2 KILOCYCLES METERS DIAL WSM Nashville, 5,000	WSB Atlanta, 10,000 KMMJ—Clay Center . . . 1,000	OT 356.9 KILOCYCLES METERS DIAL CJBC-CFCA-CKOW-CNRT Toronto, 1,000, 500, 500, 500	WT Red Deer, 1,000 CJBC-CFCA-CKOW-CNRT Toronto, 1,000, 500, 500, 500	WT 319.0 KILOCYCLES METERS DIAL WFIW-WHA Hopkinsville, Ky., 1,000 and Madison, 750 KFEL-KFXF Denver, 250 KGU—Honolulu . . . 500 WCSH—Portland, Me. . . 500	WT 288.3 KILOCYCLES METERS DIAL WJR Detroit, 5,000
5th 51.3 KILOCYCLES METERS DIAL WSM Nashville, 5,000	75th 399.8 KILOCYCLES METERS DIAL WJR Detroit, 5,000	85th 352.7 KILOCYCLES METERS DIAL KWKH-WWL Shreveport, 5,000 and New Orleans, 5,000	95th 315.6 KILOCYCLES METERS DIAL KMBC-WHB Independence, 500, and Kansas City, 1,000 KFWB-KPSN Hollywood—1,000—Pasadena KGHL—Billings . . . 250 WRC—Washington . . 500	10th 285.5 KILOCYCLES METERS DIAL WJZ New York, 30,000 WEW—St. L . . . 1,000	106th 282.8 KILOCYCLES METERS DIAL WABC New York, 5,000 KFQZ—Hollywood . . 250	
6th 54.3 KILOCYCLES METERS DIAL WEAF New York, 50,000 WAAW—Omaha 500	76th 394.5 KILOCYCLES METERS DIAL WJZ New York, 30,000 WEW—St. L . . . 1,000	86th 348.6 KILOCYCLES METERS DIAL WABC New York, 5,000 KFQZ—Hollywood . . 250	96th 312.3 KILOCYCLES METERS DIAL CFCY-CHCK 100—Charlottesville—50 CNRR-CKCK-CJBR-CHWC Regina, 500 CKGW-CFRB-CJBC	106th 282.8 KILOCYCLES METERS DIAL WABC New York, 5,000 KFQZ—Hollywood . . 250		

LOOK HERE, YOU DISTANCE HOUNDS!

Here at last is a chart by which you can identify your station as quickly as you can read your dial. It is the latest copyrighted edition of Whitman's Rapid Station Finder. Each square inch represents one broadcasting channel and it contains all the North American stations. By channels, or kilocycles, and separated in columns to permit easy finding. The cleared channels at a glance. This handy chart, printed in colors, is the leading feature of Radio Log and Lore, the thirty-two page log, atlas and program directory. Send 25c for a single copy, or 75c for a year's subscription, which includes a free art cover.

RADIO LOG AND LORE, Box 665, Kirkland, Washington

The New Jiffy Tester

Chromium-Plated Case and Accurate Meters

A NEW and improved Jiffy Tester, improved in both performance and appearance, is Model JT-N. The meters are of the moving iron type. Tested on precise batteries, they show errors not exceeding 2%. As for appearance, the case is first copper plated, then nickel plated, then chromium plated, giving a lustrous, permanent, non-peeling non-rusting finish. It is the same finish found on hardware in fine automobiles. The handle and lock strap are genuine leather.

Jiffy Tester, Model JT-N, consists of three double-reading meters, with cable plug, 4-prong adapter, test cords and screen grid cable, enabling simultaneous reading of plate voltage, plate current and filament or heater voltage (DC or AC), when plugged into the socket of any set. The ranges are filament, heater or other AC or DC: 0-10 v, 0-140 v; plate current: 0-20, 0-100 ma; plate voltage: 0-60, 0-300 v. It makes all tests former models made. Each meter is also independently accessible for each range. The entire device is built in a chromium-plated case with chromium-plated slip-cover. Instruction sheet will be found inside. Order Cat. JT-N.

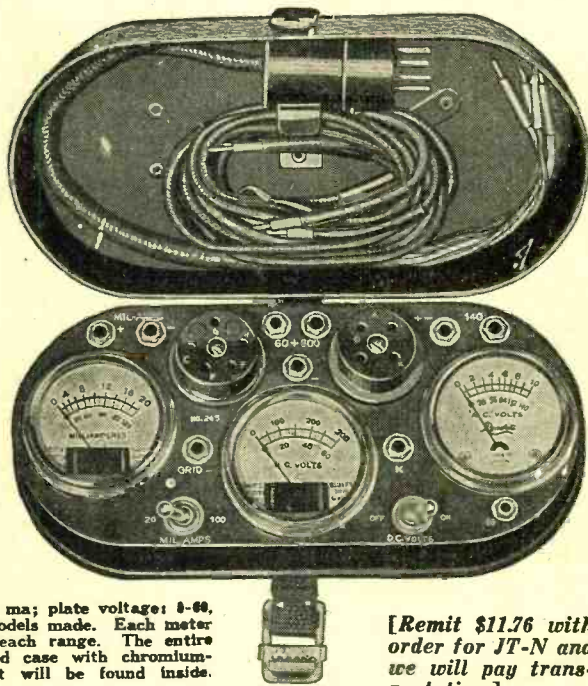

[Remit \$11.76 with order for JT-N and we will pay transportation.]

GUARANTY RADIO GOODS CO.
 143 WEST 45th STREET (Just East of Broadway) NEW YORK, N. Y.

NEW VARIABLE MU TUBE

To remedy cross-modulation and cross-talk, without circuit changes, a new AC screen grid tube has been developed, the G-51. In AC circuits where the volume control varies the grid bias or the screen voltage, or in which there is an automatic volume control, the new tube works wonders. This is the sensational tube developed by Stuart Ballantine. Price, \$3.80.

RELIABLE RADIO CO.
 143 WEST 45th St., N. Y. City

115 DIAGRAMS FREE!

115 Circuit Diagrams of Commercial Receivers and Power Supplies supplementing the diagrams in John F. Rider's "Trouble Shooter's Manual." These schematic diagrams of factory-made receivers, giving the manufacturer's name and model number on each diagram, include the MOST IMPORTANT SCREEN GRID RECEIVERS.

The 115 diagrams, each in black and white, on sheets 8 1/2 x 11 inches, punched with three standard holes for loose-leaf binding, constitute a supplement that must be obtained by all possessors of "Trouble Shooter's Manual," to make the manual complete. We guarantee no duplication of the diagrams that appear in the "Manual." Circuits include Bosch 54 D. C. screen grid; Balkite Model F; Crosley 20, 21, 22 screen grid; Eveready series 50 screen grid; Eria 224 A. C. screen grid; Peerless Electrostatic series; Philco 76 screen grid. Subscribe for Radio World for 16 weeks at the regular subscription rate of \$2.00, and have these diagrams delivered to you FREE!

Present subscribers may take advantage of this offer. Please put a cross here to expedite extending your expiration date.

Radio World, 145 West 45th St., N. Y. C.

RADIO WORLD and "RADIO NEWS"

BOTH FOR ONE YEAR @ \$7.00

You can obtain the two leading radio technical magazines that cater to experimenters, service men and students, the first and only national radio weekly and the leading monthly, for one year each, at a saving of \$1.50. The regular mail subscription rate for Radio World for one year, a new and fascinating copy each week for 52 weeks, is \$6.00. Send in \$1.00 extra, get "Radio News" also for a year—a new issue each month for twelve months. Total, 64 issues for \$7.00. RADIO WORLD, 145 West 45th Street, New York, N. Y.

Subscribers: watch the date line on your wrapper

If the expiration date line on your wrapper indicates that your subscription has expired or is about to expire, please send in renewal so that you will not miss any copies of the paper. Subscription Dept., Radio World, 145 W. 45th St., N. Y.